

Precision Cooling  
For Business-Critical Continuity

# Liebert Process Fluid Chiller™

User Manual - 1.5 - 10 Tons, 50 & 60 Hz





---

# Table of Contents

<b>PRODUCT MODEL INFORMATION</b> .....	<b>1</b>
<b>1.0 INTRODUCTION</b>	
1.1 Product Description .....	3
1.2 Optional Equipment .....	3
1.2.1 Refrigerant Gauges and Reservoir Heater .....	3
1.3 Accessory Equipment (Ship with Kits) .....	3
1.3.1 Emergency Water Source Module .....	3
1.3.2 Water Level Control and Alarm System .....	3
1.3.3 Fluid Pressure Gauge .....	3
1.3.4 Check Valve .....	4
1.3.5 Dial Thermometer .....	4
1.3.6 Relief Valve .....	4
1.3.7 Circuit Setter .....	4
1.3.8 Ball Valve .....	4
1.3.9 High Temperature Thermostat .....	4
1.3.10 Low Flow Switch .....	4
1.3.11 RCM8 Monitor .....	4
<b>2.0 INSTALLATION</b>	
2.1 Equipment Inspection .....	5
2.2 Location Considerations .....	5
2.3 Piping Connections .....	5
2.4 Electrical Connections .....	6
2.5 Preparation of Glycol Solution .....	6
2.6 Start-up .....	7
<b>3.0 OPERATION</b>	
3.1 Pre-Startup Checklist .....	10
3.2 Startup Procedure .....	10
3.3 Overview of Operation .....	11
3.4 Transformer .....	11
3.5 Low Pressure Switch Adjustment .....	11
3.6 Temperature Adjustment .....	11
3.7 High Pressure Switch .....	11
3.8 Positive Start Kit .....	12
3.9 Short Cycle Prevent Relay .....	12

---

<b>4.0</b>	<b>MAINTENANCE</b>	
4.1	Refrigeration System . . . . .	13
4.1.1	Suction Pressure . . . . .	13
4.1.2	Discharge Pressure . . . . .	13
4.1.3	Superheat . . . . .	13
4.1.4	Thermostatic Expansion Valve Operation . . . . .	14
4.1.5	Hot Gas Bypass Valve Operation . . . . .	14
4.1.6	Air Cooled Condenser . . . . .	15
4.1.7	Compressor Replacement . . . . .	15
4.2	Chilled Fluid Pump . . . . .	17
4.2.1	Pump Differential Pressure . . . . .	17
4.2.2	Pump Suction Pressure . . . . .	17
4.3	Refrigerant Gauges . . . . .	17
4.4	Reservoir Heater . . . . .	18
4.5	Reservoir Tank . . . . .	18
<b>4A.</b>	<b>8- AND 10-TON PROCESS CHILLER USER MANUAL SUPPLEMENT</b>	
4A.1	Product Description . . . . .	18A
4A.1.1	Additional Equipment . . . . .	18A
4A.2	Temperature Control for 8- and 10-Ton Process Chiller . . . . .	18C
4A.3	Temperature Setpoint for Chiller . . . . .	18E
4A.4	Flow Control . . . . .	18E
<b>5.0</b>	<b>TROUBLESHOOTING</b>	
<b>6.0</b>	<b>SEMIANNUAL MAINTENANCE INSPECTION CHECKLIST</b>	
<b>7.0</b>	<b>PARTS</b>	
7.1	Parts List . . . . .	24
<b>8.0</b>	<b>APPENDIX A: EMERGENCY WATER SOURCE MODULE</b>	
8.1	Model Numbers . . . . .	34
8.2	Typical Application . . . . .	34
8.3	Sequence of Operation . . . . .	34
8.4	System Components . . . . .	34
8.5	Installation . . . . .	35
8.6	Maintenance . . . . .	35
<b>9.0</b>	<b>APPENDIX B: THE WATER LEVEL CONTROL MODULE</b>	
9.1	Model Number . . . . .	40
9.2	Typical Application . . . . .	40
9.3	Sequence of Operation . . . . .	40
9.4	System Components . . . . .	41
9.5	Installation . . . . .	41
9.6	Maintenance . . . . .	42

---

---

## Figures

Figure 1	Dimensional Data and Piping Connections . . . . .	8
Figure 2	Electrical Connections . . . . .	9
Figure 2A	General piping arrangement—8- and 10-ton air cooled models . . . . .	9A
Figure 2B	Cabinet and floor planning dimensional data—8- and 10-ton air cooled models . . . . .	9B
Figure 2C	Electrical field connections—8- and 10-ton air cooled models . . . . .	9C
Figure 2D	Cabinet and floor planning dimensional data, 8- and 10-ton air cooled with thermal storage tank cabinet . . . . .	9D
Figure 3	Hot Gas Bypass. . . . .	15
Figure 3A	Process chiller pump performance, 60 Hz . . . . .	18B
Figure 3B	Piping bypass to evaporator inlet . . . . .	18C
Figure 3C	Electronic hot gas bypass valve . . . . .	18C
Figure 3D	Hot gas bypass control board connections. . . . .	18D
Figure 3E	Temperature sensor resistance . . . . .	18E
Figure 4	The Emergency Water Source Module . . . . .	33
Figure 5	Emergency Water . . . . .	34
Figure 6	General Piping Arrangement. . . . .	36
Figure 7	Cabinet Dimensions and Mounting. . . . .	37
Figure 8	Electrical Connections . . . . .	38
Figure 9	Emergency Switchover Electrical Schematic . . . . .	39
Figure 10	Water Level Control Module . . . . .	40
Figure 11	Water Level Control and Chiller System . . . . .	40
Figure 12	General Piping Arrangement at WLC Module . . . . .	43
Figure 13	Cabinet Dimensions and Mounting. . . . .	44
Figure 14	Electrical Connections at WLC Module . . . . .	45
Figure 15	Electrical and Piping Connections at the Process Chiller . . . . .	46
Figure 16	Level Control and Alarm Option Module Electrical Schematic. . . . .	47

## Tables

Table 1	Model Number Designation . . . . .	1
Table 2	Typical Propylene Glycol Data. . . . .	7
Table 3	Glycol Volume . . . . .	7
Table 4	Typical Ethylene Glycol Data . . . . .	7
Table 5	Dimensional Data in.(mm). . . . .	8
Table 5A	Dimensional data, 8- and 10-ton air cooled. . . . .	9B
Table 5B	Dimensional Data, 8-10 ton air-cooled models with thermal storage tank cabinet . . . . .	9D
Table 6	Pump Suction . . . . .	17
Table ?	Chilled Fluid Pump Troubleshooting . . . . .	19
Table 8	Compressor Troubleshooting . . . . .	20
Table 9	Refrigeration System Troubleshooting . . . . .	21
Table 10	Condenser Fan Troubleshooting . . . . .	22
Table 11	Fans and Motors. . . . .	24
Table 12	Compressor and Refrigerant Valves . . . . .	24
Table 13	Quick Disconnect Couplings . . . . .	26
Table 14	Fluid Controls . . . . .	26
Table 15	Electrical . . . . .	27
Table 16	Exterior Panels . . . . .	28
Table 17	Emergency Water Source Piping Connection Sizes . . . . .	36
Table 18	Emergency Water Source Electrical Data. . . . .	38
Table 19	WLC Module Connection Sizes . . . . .	43
Table 20	WLC Module Electrical Data . . . . .	45

---

---

---

# PRODUCT MODEL INFORMATION

**Table 1 Model Number Designation**

PS036A-PB2					
PS	036	A-	P	B	2
Process Fluid Chiller	Nominal Capacity in Thousand BTUH	A- = Air Cooled	A = 460 60 Hz 3-phase  P = 208/230 60 Hz 1-phase  M = 380/415 50 Hz 3-phase  N = 200/230 50 Hz 3-phase  W = 200/230 50 Hz 1-phase  Y = 208/230 60 Hz 3-phase	O = No options  G = Gauge/Heater  S = Stainless Steel Pump  B = Gauge/Heater/SS Pump	2 = Revision Level

---



---

## 1.0 INTRODUCTION

---

### 1.1 Product Description

The Process Fluid Chiller is a self contained air cooled chiller containing a hermetic compressor (four ton model has a scroll compressor), copper tube/aluminum fin condenser coil, direct drive propeller condenser fan and motor, Lee-Temp low ambient head pressure control, high pressure and low pressure switches, filter drier, sight glass, expansion valve, hot gas bypass valve, solenoid valves, and crankcase heater. The insulated fluid circuit contains a 304 stainless steel close coupled centrifugal pump, stainless steel reservoir and expansion tank, two isolating ball valves, and unions at the pump inlet and discharge.

### 1.2 Optional Equipment

#### 1.2.1 Refrigerant Gauges and Reservoir Heater

This option is factory installed, and includes a 250 watt immersion heater with thermostat for the fluid reservoir. The adjustable heater thermostat is set to turn on at 35°F (1.7°C) and turn off at 42°F (5.6°C), to maintain minimum reservoir temperatures during low ambient periods. The suction and discharge refrigerant gauges are 2-1/2 inch (63 mm) diameter, with stainless steel housings.

### 1.3 Accessory Equipment (Ship with Kits)

The following accessories are shipped separately. This facilitates customization and permits installation at indoor locations more accessible to the operator.

#### 1.3.1 Emergency Water Source Module

This module is a prepped and wired assembly which consists of an almond colored, baked on polyurethane painted enclosure, RCM4 monitor, adjustable time delay relays, flow switch, high temperature thermostat, solenoid valves, ball valves on the entering and leaving lines connected to the chiller, a fluid pressure gauge and valve, and a dial thermometer on the entering fluid line. It also includes a ball valve and double check back flow preventer on the entering “city water” line. The module has a local display for high fluid temperature, loss of fluid flow, and emergency water. It also has a non-powered common alarm contact. It requires a 120 volt, single phase power input. This module is for use on systems that circulate water as the cooling medium (it is not for use with glycol systems). It automatically switches to emergency water (normally city water) on a high fluid temperature alarm, or loss of fluid flow alarm.

#### 1.3.2 Water Level Control and Alarm System

This accessory consists of a multi-point level switch, flow regulating solenoid valve with integral strainer, double check back flow preventer, automatic air vent, time delay relays, and prewired RCM4 monitor. This accessory is to be used only when water is used as the cooling medium (not glycol). All items are field installed.

It has a local display for high fluid level, low fluid level, fluid fill and fluid fill lockout, as well as separate non-powered contacts for high fluid level, low fluid level, and fluid fill. It also has a non-powered common alarm contact. It requires a 120/60/1 power input. It automatically adds water to the reservoir in the chiller when the water level drops below a set level, and continues until the water rises to a preset level.

An alarm circuit activates if the tank has not filled after a preset time period, and a lock out circuit deenergizes the solenoid valve if the tank has not filled after an additional time period. The level switch contains additional high and low level alarm points.

#### 1.3.3 Fluid Pressure Gauge

An analog gauge with 2-1/2 inch (63 mm) dial for panel mounting, and bourdon tube for monitoring supply or return pressure. Scale is 0 to 100 PSI (0 to 690 kPa).

---

#### **1.3.4 Check Valve**

Brass body, swing check valve, for installation in the fluid piping to prevent back flow.

#### **1.3.5 Dial Thermometer**

A 2-1/2 inch (63 mm) dial thermometer, for panel mounting, for supply or return fluid temperature measurement. Dual scale is 20°F to 130°F, and -10°C to 55°C.

#### **1.3.6 Relief Valve**

A brass body, 3/4 inch FPT valve, set at 50 PSI for installation in the fluid piping. The Process Fluid Chiller is supplied with a relief valve as standard equipment. An additional optional relief valve is required only for special applications. (Note: If a special pump is selected, a special relief valve may be required.)

#### **1.3.7 Circuit Setter**

A bronze body, calibrated balancing valve for flow balance, metering and shut off.

#### **1.3.8 Ball Valve**

Brass body, 1/4 turn, for isolation of fluid piping components, as a service aid.

#### **1.3.9 High Temperature Thermostat**

A remote bulb, adjustable thermostat. Provides alarm contact when the fluid temperature rises above design limit. Adjustable range is 40°F to 90°F (4.4° to 32°C).

#### **1.3.10 Low Flow Switch**

Brass body flow switch. Provides alarm contact when fluid flow falls below design limit.

#### **1.3.11 RCM8 Monitor**

The RCM8 is an eight-point dry contact monitoring system that can be used as a stand alone panel, dial an alarm to a remote location, or connected to a Liebert SiteScan system. The RCM8 is equipped with two RS-232 ports for a local VDT and modem connection, eight LED's, a common alarm contact, and an audible alarm for local annunciation. The RCM8 requires 120 or 220 VAC, 50 or 60 Hz, and has an internal battery rated for one hour of operation.

---

## 2.0 INSTALLATION

---

### 2.1 Equipment Inspection

Upon arrival of the unit, inspect all items for either visible or concealed damage. Damage should be immediately reported to the carrier and a damage claim filed.

### 2.2 Location Considerations

The air cooled chiller should be located for maximum security and maintenance accessibility. Avoid ground level sites with public access or areas which contribute to heavy snow or ice accumulations. To assure adequate air supply, locate chiller in a clean air area, away from loose dirt and foreign matter that may clog the coil. In addition, chillers should not be located in the vicinity of steam, hot air or fume exhausts. Also, chillers should be located no closer than three feet (1 meter) from a wall, obstruction or adjacent unit.

Install chillers in a level position to assure proper refrigerant flow and oil return. For ground installation, a concrete pad will provide adequate support. Chiller support rails have mounting holes for securing the chiller to the concrete pad. For roof installation, mount chillers on steel supports in accordance with local codes. To minimize sound and vibration transmission, mount steel supports across load bearing walls.

Prepare the location(s) for the unit. The unit includes both chiller and condensing sections mounted together, with connecting wiring and piping. Bolt the unit to the floor or slab.

### 2.3 Piping Connections



#### CAUTION

**Galvanized pipe must not be used in Glycol Systems.**

Connect the chiller unit to the coolant loop of the processing equipment to be cooled by chilled water. Install a shut-off valve in each line so that equipment can be isolated for maintenance. Insulate the coolant lines to prevent the condensation of water from the air on the pipes.

The connections are 3/4 inch or 1 inch NPT female, depending on model. The supply line (to the computer) and return line (from the computer) are labeled on the unit.

Install all accessories supplied with your unit. These may include switchover modules, flow switch, valves, gauges, and monitors.

Flush the coolant loop to remove foreign materials before filling.

Use a mixture of water and ethylene glycol (or propylene glycol) if the chiller will be outdoors and subjected to freezing temperatures. Refer to **2.5 - Preparation of Glycol Solution**.

Fill system with enough coolant for chiller unit, lines, and equipment to be cooled. Filling and air bleeding can be done at the schrader fittings on the chiller. Make sure to bleed all air out of the system from the highest point in the loop.



#### NOTE

*Do not bleed air from the coolant reservoir tank. Fill the system to put the fluid level in the tank at the height of the sightless. The air volume in the top of the tank is required to allow for coolant expansion, and for the proper functioning of the optional WLC accessory.*



#### CAUTION

**To prevent leaks, the coolant loop should not exceed the designed maximum working pressure of 50 PSI (344 kPa). For installations using an alternate water source above this rating, isolation valves or a pressure reducing valve (customer supplied) is required.**

---

## 2.4 Electrical Connections

Connect unit to the required AC power source as indicated on the unit nameplate, through a remote on/off switch (field supplied). Electrical service shall conform to national and local electrical codes. Refer to unit nameplate for wire size amps (WSA), full load amps (FLA), and overcurrent protection device (OPD) required. Refer to electrical schematic when making connections.



### WARNING

**USE VOLTMETER TO MAKE SURE POWER IS TURNED OFF BEFORE MAKING ANY ELECTRICAL CONNECTIONS.**



### CAUTION

**Liquid-tight conduit fittings are required where wires are brought into the electrical enclosure.**



### CAUTION

**In three phase models, pump and compressor motors are phase synchronized at the factory. At initial installation, change phase leads outside of the chiller to obtain proper rotation for the pump and compressor.**

Connect all control and monitoring options required for your installation, including remote shut-down.

## 2.5 Preparation of Glycol Solution

Typical ethylene glycol manufacturers and suppliers are Union Carbide (Ucartherm) or Dow Chemical Company (Dowtherm SR-1). Propylene glycol, such as Dow Chemical Company (Dowfrost HD), may also be used in the chiller. Glycols are supplied with an inhibitor and do not contain an anti-leak formula.



### NOTE

*For glycol solution preparation and periodic testing, follow manufacturer's recommendations. Do not mix products of different manufacturers.*



### CAUTION

**Automotive anti-freeze is unacceptable and must not be used.**

Commercial glycol, when pure, is generally less corrosive to the common metals of construction than water itself. Aqueous solutions of these glycols, however, assume the corrosivity of the water from which they are prepared and may become increasingly corrosive with use if not properly inhibited.

There are two basic types of corrosion inhibition; they are classified as corrosion inhibitors or environmental stabilizers. The corrosion inhibitors function by forming a surface barrier which protects the metals from attack. Environmental stabilizers, while not corrosion inhibitors in the strict sense of the word, decrease corrosion by stabilizing or favorably altering the overall environment. An alkaline buffer, such as borax, is a simple example, since its prime purpose is to maintain an alkaline condition (pH above 7).

The quality of the water used for dilution must be considered because water may contain corrosive elements which reduce the effectiveness of the inhibited formulation. Preferably, surface

water that is classified as soft (low in chloride and sulfate ion content—less than 100 parts per million each) should be used. Before an inhibited glycol solution is charged into a new or old system, residual contaminants such as sludge, rust, brine deposits, oil, etc., should be flushed out as completely as possible. Avoid the use of strong acid cleaners. However, if they are required, inhibited acids should be considered. In any event, assure that the cleaning agent is completely removed before charging with glycol. Contact your Liebert representative for additional recommendations.

## 2.6 Start-up

Refer to **3.0 - Operation** for start-up check list and procedure.

**Table 2 Glycol Volume**

Chiller Tank, Evaporator and Internal Piping	
Model (Tons)	Glycol Volume gal. (liters)
1.5	7.1 (26.9)
2.0	7.2 (27.3)
2.0	9.8 (37.1)
4.0	9.9 (37.5)
5.0	10.0 (37.9)

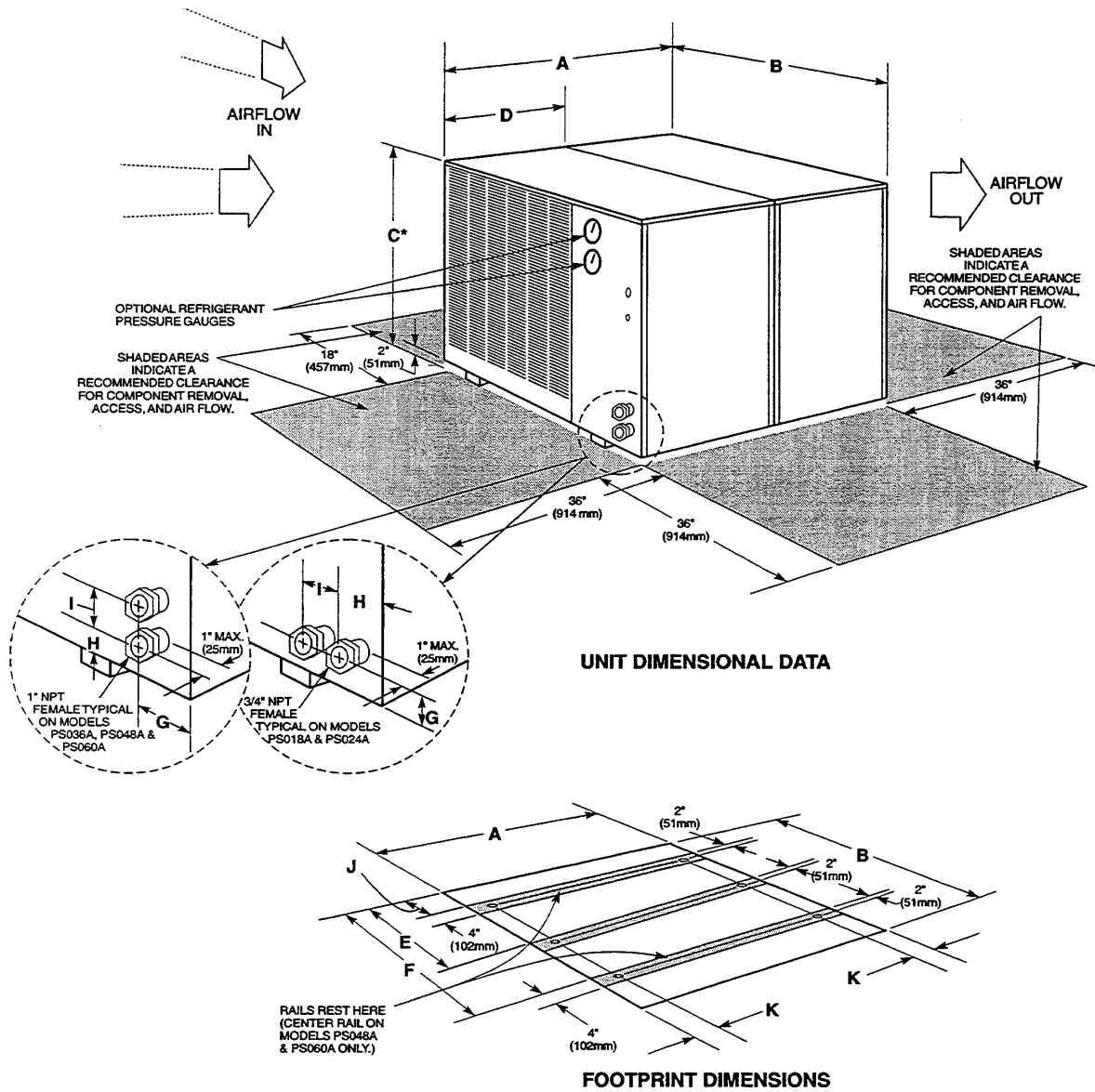
**Table 3 Typical Ethylene Glycol Data**

% Glycol by VOLUME	0	10	20	30	40	50
Freezing Point °F (°C)	32 (0)	25 (-3.9)	16 (-8.9)	5 (-15.0)	-10 (-23.3)	-32 (-35.5)
Apparent Specific Gravity @ 50°F	1.000	1.014	1.028	1.042	1.057	1.071

**Table 4 Typical Propylene Glycol Data**

% Glycol by VOLUME	0	10	20	30	40	50
Freezing Point °F (°C)	32 (0)	25 (-3.9)	20 (-6.7)	10 (-12.2)	-5 (-20.6)	-30 (-34.4)
Apparent Specific Gravity @ 50°F	0.999	1.008	1.018	1.028	1.039	1.048

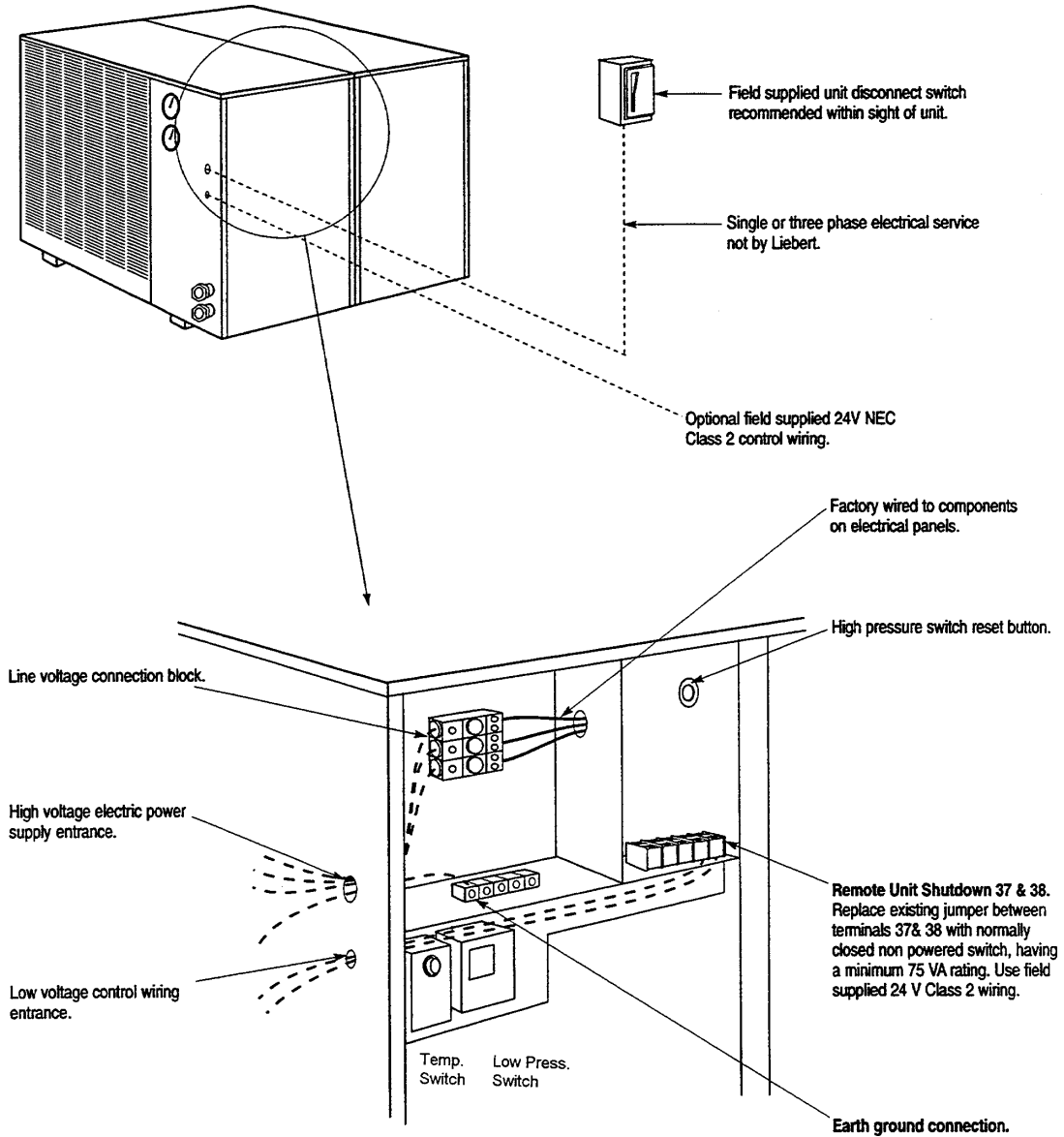
**Figure 1 Dimensional Data and Piping Connections**



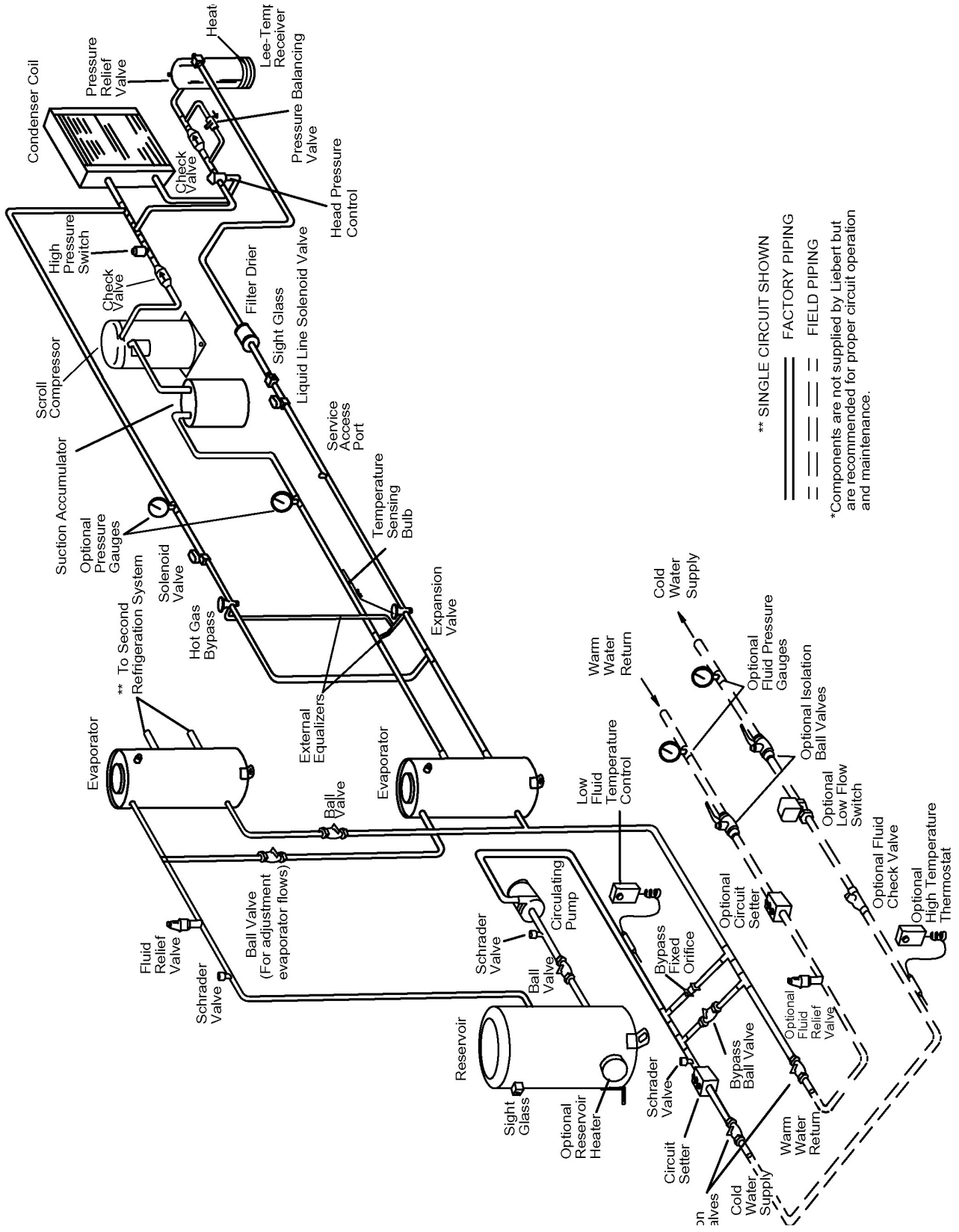
**Table 5 Dimensional Data in. (mm)**

Model	DIMENSIONAL DATA IN. (mm)											Weight lb. (kg)
	A	B	C	D	E	F	G	H	I	J	K	
PS018A	36 (914)	1/16 (1018)	25-1/4 (641)	18 (457)	N/A	27-7/32 (691)	2 (51)	1-3/8 (35)	2-1/4 (57)	8-27/32 (225)	1-15/16 (49)	314 (142)
PS024A	36 (914)	40-1/16 (1018)	25-1/4 (641)	18 (457)	N/A	27-7/32 (691)	2 (51)	1-3/8 (35)	2-1/4 (57)	8-27/32 (225)	1-15/16 (49)	344 (156)
PS036A	36-1/8 (918)	48-3/16 (1224)	32-1/2 (825)	18 (457)	N/A	34-3/32 (866)	1-7/8 (48)	2 (51)	2-1/2 (64)	10-3/32 (256)	2 (51)	425 (193)
PS048A	36-1/8 (918)	53-3/16 (1351)	38-1/2 (978)	18 (457)	24-19/32 (625)	39-3/32 (993)	2-1/2 (64)	2 (51)	2-1/2 (64)	10-3/32 (256)	2 (51)	532 (241)
PS060A	36-1/8 (918)	53-3/16 (1351)	38-1/2 (978)	18 (457)	24-19/32 (625)	39-3/32 (993)	2-1/2 (64)	2 (51)	2-1/2 (64)	10-3/32 (256)	2 (51)	582 (287)

**Figure 2 Electrical Connections**

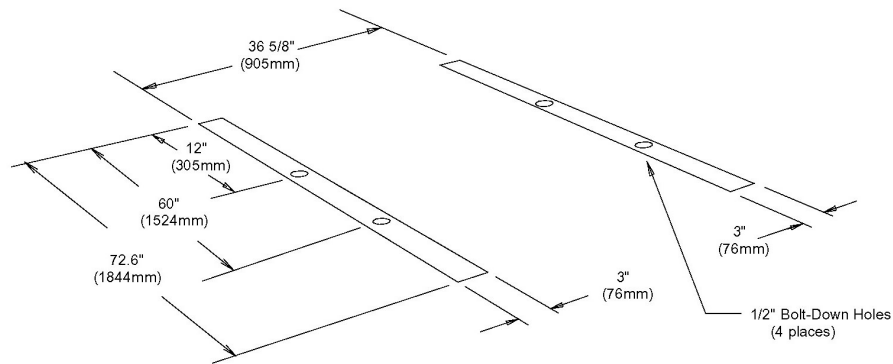
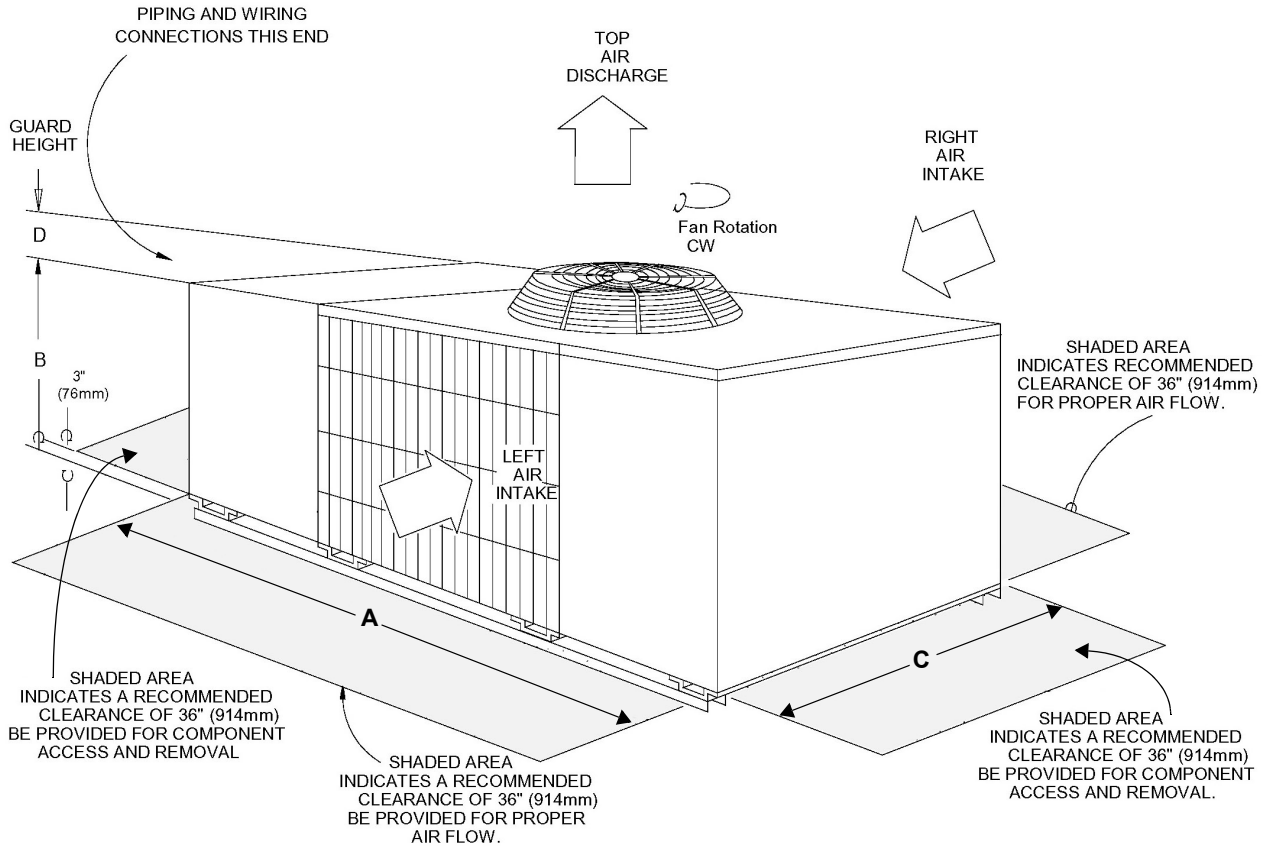


**Figure 2A General piping arrangement—8- and 10-ton air cooled models**





**Figure 2B Cabinet and floor planning dimensional data—8- and 10-ton air cooled models**

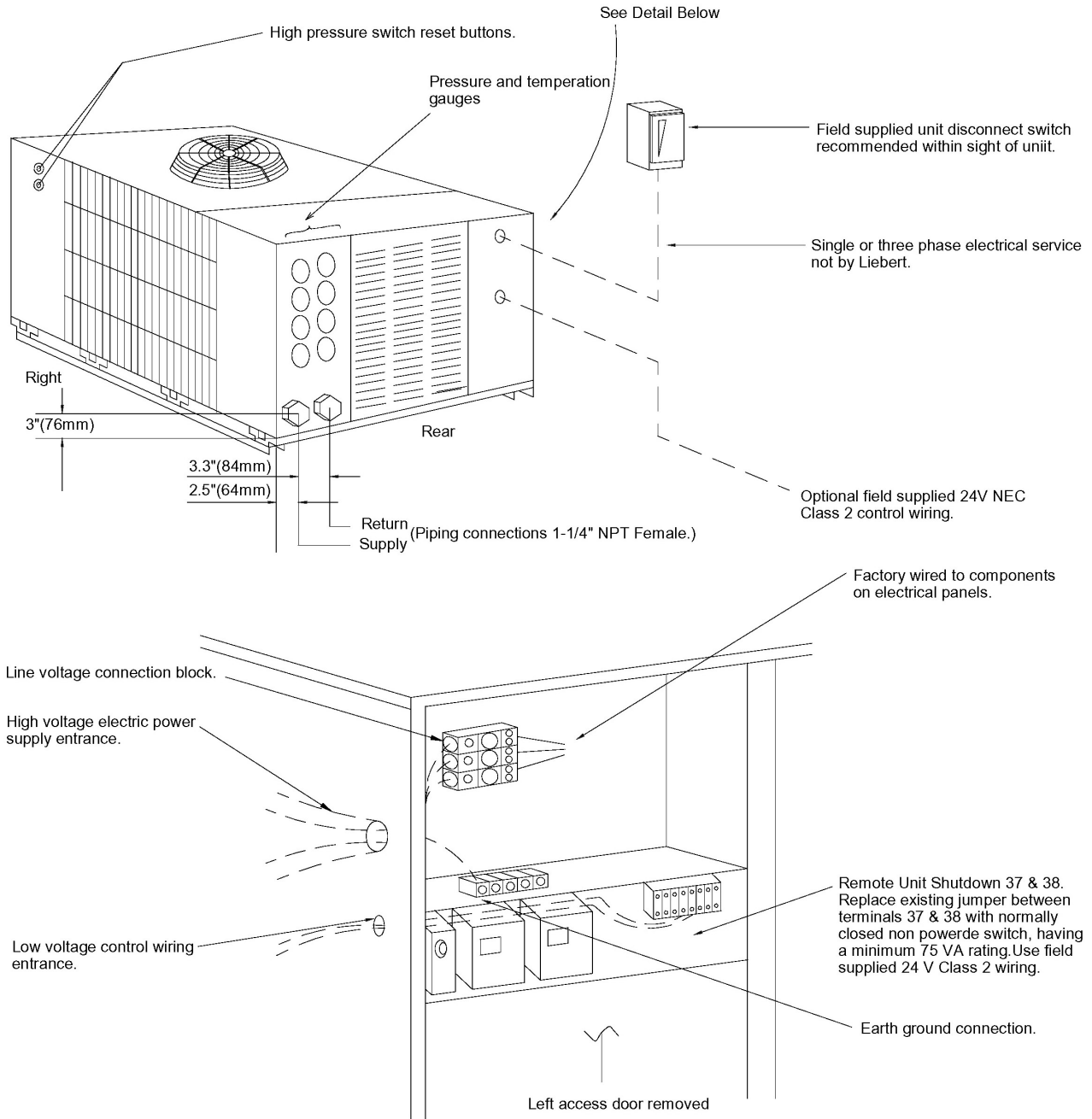


**FOOTPRINT DIMENSIONS**

**Table 5A Dimensional data, 8- and 10-ton air cooled**

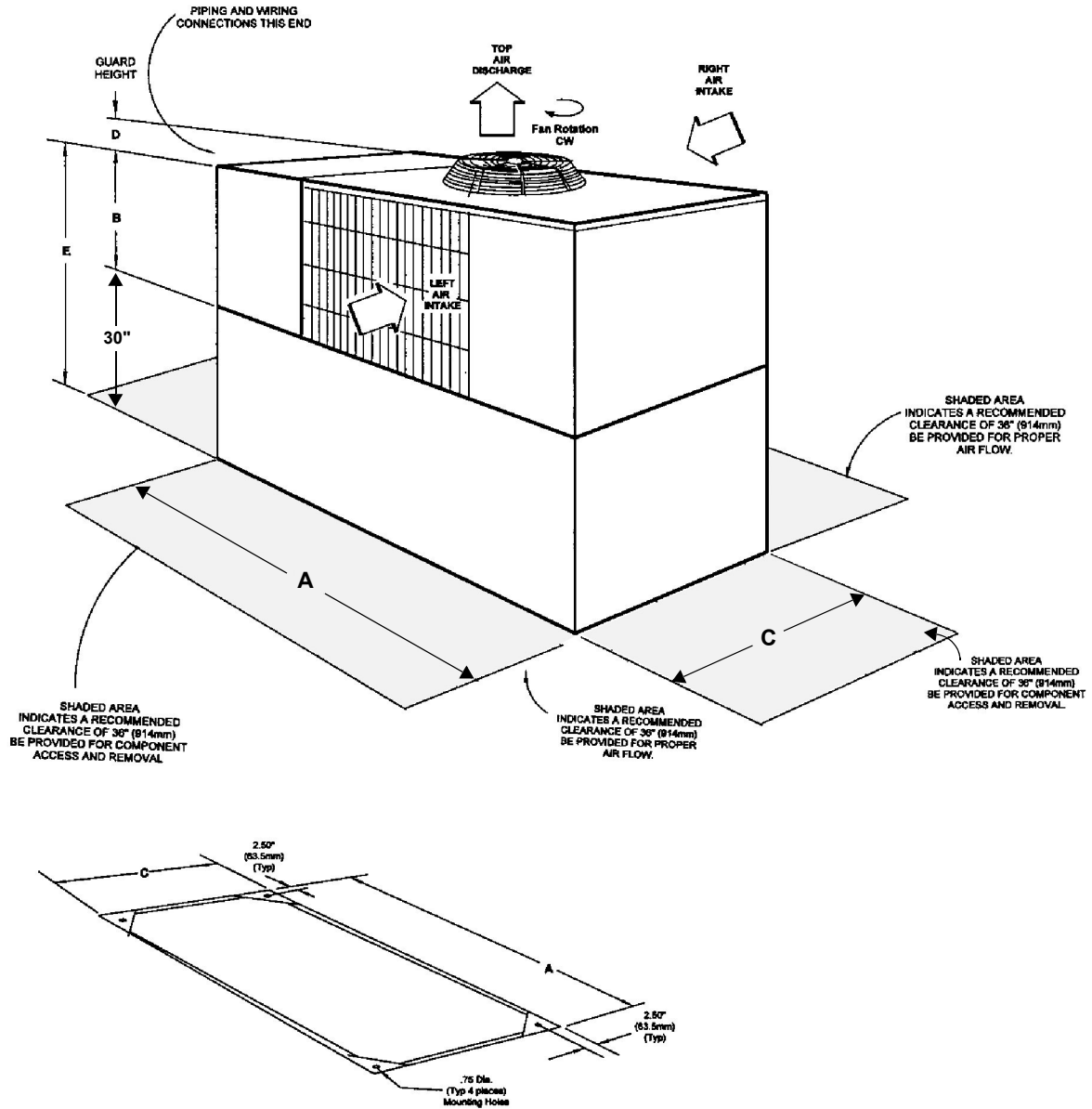
Model Numbers	Dimensional Data in. (mm)					Module Weight Net. lbs.(kg)
	50 HZ	A	B	C	D	
60 HZ						
PF096A	PS095A	77	39-1/4	38-1/2	5-1/2	750
PS120A	PS119A	(1956)	(997)	(978)	(140)	(340)

**Figure 2C Electrical field connections—8- and 10-ton air cooled models**



NOTE: Refer to specification sheet for full load amp. and wire size amp. ratings.

**Figure 2D Cabinet and floor planning dimensional data, 8- and 10-ton air cooled with thermal storage tank cabinet**



**Table 5B Dimensional Data, 8-10 ton air-cooled models with thermal storage tank cabinet**

Model Numbers	Dimensional Data in (mm)					Module Weight Storage Tank (empty*) lbs (kg)	Capacity gal (L)
	A	B	C	D	E		
60 Hz							
PS096A	77	39-1/4	38-1/2	5-1/2	69-1/4	1170	100
PS120A	(1956)	(997)	(978)	(140)	(1759)	(531)	(380)

\* Note: Add weight of fluid for operating weight

---

## 3.0 OPERATION

---

### 3.1 Pre-Startup Checklist

1. Proper clearances for service access have been maintained around the equipment.
2. Equipment is level and mounting fasteners are tight.
3. Piping completed to fluid loop.
4. System filled with proper fluid level and air bled, per installation instructions in **2.3 - Piping Connections**. See also instructions for optional accessories located in Sections 8 and 9 as required.
5. Relief valve drain line connected (if required) 5/8 inch OD copper.
6. All piping connections are tight.
7. Line voltage to power wiring matches equipment nameplate.
8. Power wiring connections completed to customer-supplied disconnect switch and process chiller unit, including earth ground.
9. Power line circuit breakers or fuses have proper ratings for equipment installed.
10. Control wiring connections completed (if required), including wiring to optional controls.
11. All wiring connections are tight.
12. Foreign materials have been removed from in and around all equipment installed (shipping materials, construction, materials, tools, etc.).
13. Fan and pump rotate freely without unusual noise.
14. Make sure all optional accessories selected for this installation have been installed.

### 3.2 Startup Procedure

1. Complete pre-startup checklist.
2. Close the customer-supplied disconnect switch to energize the unit. The same switch will also stop the unit. Check for proper voltage.

For initial startup, or if the unit has been idle for some time, follow the procedure below:



#### CAUTION

**The compressor crankcase heater is energized as long as power is supplied to the unit. If the main switch is disconnected for long periods, do not attempt to start a condensing unit until 8 hours after applying power. This allows enough time for all liquid refrigerant to be driven out of the compressor. Note that this is especially important at low ambient temperatures, and for units with Lee-Temp receivers.**

3. Verify that the fluid pump is rotating correctly (clockwise from motor end).
4. On units with 3 phase scroll compressors, verify rotation is in proper direction. Refer to **2.4 - Electrical Connections**.
5. Turn the Temperature Control adjustment knob counterclockwise until the liquid line solenoid valve and hot gas bypass solenoid valve are energized.
6. Adjust low pressure switch if required per **3.5 - Low Pressure Switch Adjustment**.
7. Adjust temperature control per **3.6 - Temperature Adjustment**.
8. Adjust hot gas bypass per **4.1.5 - Hot Gas Bypass Valve Operation** if required.
9. Test for proper operation of all functions, including temperature and pressures of chilled fluid and refrigerant.
10. Inspect all piping connections for leaks during initial operation.

---

### 3.3 Overview of Operation

If there is an increase in leaving fluid temperature beyond the setpoint, the thermostat will energize the liquid line solenoid valve and the discharge bypass solenoid valve. Refrigerant will flow through the evaporator to the compressor. The compressor is activated when the low pressure switch senses sufficient pressure (see **3.5 - Low Pressure Switch Adjustment**).

When chilled fluid temperature drops below the thermostat differential setting (typically 3°F, 1.7°C), the liquid line solenoid valve is deenergized and the compressor pumps down.

Condenser fan motor operation is regulated by the compressor operation. They operate simultaneously.

The air cooled condensing section uses a propeller fan. It also includes a Lee-Temp flood back head pressure control, which includes a receiver and a head pressure control valve. This control system floods the condenser coil with refrigerant that is warmed in the receiver to maintain head pressure during low ambient temperature operation.

### 3.4 Transformer

Transformer is line voltage primary with 24 volt 75 VA secondary. This transformer is used to operate various relays and contacts in the control circuit.

#### Circuit Breaker

The control voltage circuit is protected by a manual reset 3.2 Amp circuit breaker. Circuit breaker is mounted to a bracket on the transformer.

#### Reset Button

If the reset button is in the extended position, eliminate all possible shorts in that circuit then depress the reset button.

### 3.5 Low Pressure Switch Adjustment

The low pressure switch is located under the chiller control box. The “cut out” is the point at which the switch will close. The “cut in” is the point at which the switch will open. See below for settings required for fluid at your installation. The factory settings are for water.

Fluid	Cut Out	Cut In
Water	53 PSI	65 PSI
40% Glycol	40 PSI	50 PSI
50% Glycol	30 PSI	40 PSI

### 3.6 Temperature Adjustment

The temperature control (thermostat) is located under the chiller control box. The setpoint is the point at which the switch will close. The differential is the temperature drop required to open the switch.

Factory Setpoint	52°F
Allowable Range	40° to 70°F
Differential	3°F

### 3.7 High Pressure Switch

All models are equipped with a non-adjustable high pressure switch. This manual reset switch sets the maximum discharge pressure of the compressor. If the pressure rises to the setpoint of 360 PSI, the switch will shut off the compressor.

---

### **3.8 Positive Start Kit**

All units have a non-adjustable time delay relay that bypasses the low pressure switch for three minutes. This ensures positive starting during periods of low outdoor temperature.

### **3.9 Short Cycle Prevent Relay**

All units have a non-adjustable time delay relay that prevents a compressor start within three (3) minutes of a compressor shut off.

---

## 4.0 MAINTENANCE

---

### 4.1 Refrigeration System



#### CAUTION

Only qualified personnel should perform refrigeration system maintenance.

#### Periodic Inspections

Each month the components of the refrigeration system should be inspected for proper function and signs of wear. Since in most cases evidence of malfunction is present prior to component failure, periodic inspections can be a major factor in the prevention of most system failures.

#### Liquid Line Sight Glass

The liquid line has a sight glass that indicates liquid refrigerant flow and the presence of moisture. Excessive bubbles in the sight glass may indicate a shortage of refrigerant or a restriction in the liquid line. The moisture indicator changes from green to yellow when moisture is present in the system.

#### Refrigerant Charge

The unit is supplied from the factory fully charged. If refrigerant must be replaced, weigh in the charge specified on the serial tag (rather than using the sight glass to determine a full charge).

#### 4.1.1 Suction Pressure

Suction pressure will vary with load conditions. The low pressure switch will shut the compressor down if suction pressure falls below the cut-out setting. High suction pressure reduces the ability of the refrigerant to cool compressor components and can result in compressor damage. Minimum (pressure switch cut-out setting) and maximum (design operating) suction pressures are shown below.

Minimum Suction Pressure

53 PSI for water systems (factory setting)

40 PSI for 40% Glycol

30 PSI for 50% Glycol

Maximum Suction Pressure      92 PSI

#### 4.1.2 Discharge Pressure

Discharge Pressure can be increased or decreased by load conditions or condenser efficiency. The high pressure switch will shut the compressor down at its cut-out setting.

Maximum Discharge Pressure      360 PSI

#### 4.1.3 Superheat

Superheat can be adjusted by the Thermostatic Expansion Valve (TEV).

To determine superheat:

1. Measure the temperature of the suction line at the point the TEV bulb is clamped.
2. Measure the gauge pressure of the compressor suction line.
3. Add the estimated pressure drop between bulb location and suction valve.
4. Convert the sum of the two pressures to the equivalent temperature.
5. Subtract this temperature from the actual suction line temperature. The difference is superheat.

---

#### 4.1.4 Thermostatic Expansion Valve Operation

The thermostatic expansion valve (TEV) keeps the evaporator supplied with enough refrigerant to satisfy load conditions. It does not turn the compressor on or off, but correct valve adjustment is necessary for proper system operation.

Determine TEV operation by measuring superheat (see 4.1.3 - **Superheat**). If too little refrigerant is being fed to the evaporator, the superheat will be high; if too much refrigerant is being supplied, the superheat will be low. The correct superheat setting is between 10° and 15° F (5.5° and 8.3° C).

##### Adjustment

To adjust the superheat setting, proceed as follows:

1. Remove the valve cap at the bottom of the valve.
2. Turn the adjusting stem to change the superheat (CW to increase, CCW to decrease).



##### NOTE

*Make no more than 1/4 turn of the stem at a time. As long as thirty minutes may be required for the new balance to take place.*

#### 4.1.5 Hot Gas Bypass Valve Operation

The hot gas bypass is inserted between the compressor discharge line and the outlet side of the expansion valve.

When the system is operating at full capacity, the valve remains closed. If the load decreases, the evaporator will get colder. When the evaporator is too cold, the internal pressure in the evaporator drops and allows the hot gas bypass valve to open. Hot gas then mixes with the liquid coolant on the discharge side of the expansion valve raising the temperature and pressure in the evaporator. The net result is a reduction in the cooling capacity of the unit to match the load.

The leaving fluid temperature will determine the hot gas bypass valve setting, as well as the compressor suction gauge pressure.

##### Adjustment

After determining the desired leaving fluid temperature, the following procedure should be used to adjust the hot gas bypass valve:

1. Install suction and discharge pressure gauges on the compressor to monitor refrigeration.
2. Set the control thermostat at 3° F (1.7° C) below required leaving fluid temperature. Measure the leaving fluid temperature by strapping a thermometer to the leaving fluid piping.



##### NOTE

*Compressor should not cycle off and on to match a constant load.*

3. While adjusting the hot gas bypass valve for proper leaving fluid temperature, maintain nominal load on chiller.



- a. Remove the TOP adjusting nut from the valve.
- b. Insert an Allen wrench in the brass hole at the top of the valve in the adjusting port and turn **CLOCKWISE** if a **HIGHER** leaving fluid temperature is required, or **COUNTERCLOCKWISE** if a **LOWER** leaving fluid temperature is required.
- c. After obtaining the leaving fluid temperature required, reinstall the adjusting nut tightly on the valve making sure that there are no leaks.
- d. Let the system operate at nominal load for approximately 10 to 15 minutes (longer if thermal storage tank is used) to make sure that the suction pressure is within the range desired.



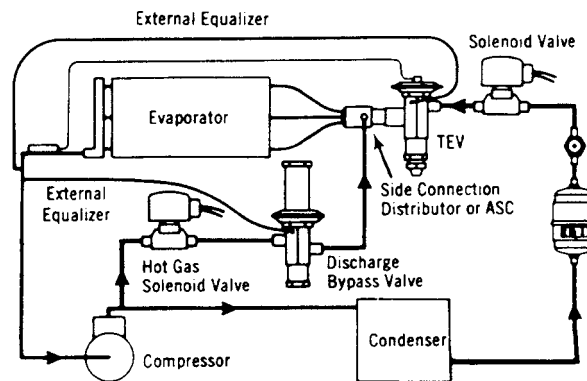
**NOTE**

*There is a fluctuation of 3 to 6 PSI of the suction pressure due to the differential on the hot gas bypass.*

4. Final Adjustment

- a. For applications with constant load, re-adjust the control thermostat to the required leaving fluid temperature.
- b. For applications with varying load, operate the system at both minimum and maximum loads to verify adequate control of leaving fluid temperature.

**Figure 3 Hot Gas Bypass**



**4.1.6 Air Cooled Condenser**

Restricted airflow through the condenser coil will reduce the operating efficiency of the unit and can result in high compressor head pressure and loss of cooling.

Clean the condenser coil of all debris that will inhibit air flow. This can be done with compressed air or commercial coil cleaner. Check for bent or damaged coil fins and repair as necessary. In winter, do not permit snow to accumulate around the sides or underneath the condenser.

Check all refrigerant lines and capillaries for vibration isolation. Support as necessary. Visually inspect all refrigerant lines for signs of oil leaks.

**4.1.7 Compressor Replacement**

Infrequently a fault in the motor insulation may result in a motor burn, but in a properly installed system burnouts rarely occur. Of those that do, most are the effects of mechanical or lubrication failures, resulting in the burnout as a secondary consequence.

If problems that can cause compressor failures are detected and corrected early, a large percentage can be prevented. Periodic maintenance inspections by alert service personnel on the lookout for abnormal operation can be a major factor in reducing maintenance costs. It is easier and far less costly to take the steps necessary to ensure proper system operation than it is to allow a compressor to fail and require replacement.

---

When troubleshooting a compressor, check all electrical components for proper operation.

- Check all fuses.
- Check Hi-Lo Pressure switch
- If a compressor failure has occurred, determine whether it is an electrical or mechanical failure.

### **Mechanical Failure**

A mechanical compressor failure will be indicated by no burned odor. The motor will attempt to run. If you have determined that a mechanical failure has occurred, the compressor must be replaced.

If a burnout does occur, correct the problem that caused the burnout and clean the system. It is important to note that successive burnouts of the same system are usually caused by improper cleaning.

### **Electrical Failure**

An electrical failure will be indicated by a distinct pungent odor. If a severe burnout has occurred, the oil will be black and acidic.

In the event that there is an electrical failure and a complete burnout of the refrigeration compressor motor, the proper procedures must be performed in order to clean the system to remove any acids that would cause a future failure.



#### **CAUTION**

**Damage to a replacement compressor caused by improper system cleaning constitutes abuse under the terms of the warranty, and the WARRANTY WILL BE VOID.**

There are two kits that can be used with a complete compressor burnout—Sporlan System Cleaner and Alco Dri-Kleener. Follow the manufacturer's procedure.



#### **CAUTION**

**Avoid touching or contacting the gas and oils with exposed skin. Severe burns will result. Use long rubber gloves in handling contaminated parts.**

### **Compressor Replacement Procedure**

Replacement compressors are available from your Liebert supplier. They will be shipped in a permanent crate to the job site as required by the service contractor.

Upon shipping a replacement compressor, the service contractor will be billed in full for the compressor until the replacement has been returned to the factory.

The compressor should be returned in the same container used for shipping to the job. The possible damage causes or conditions that were found should be recorded by marking the compressor return tag.

1. Disconnect power.
2. If your system does not include optional gauges, attach suction and discharge gauges to access fittings.
3. Recover refrigerant using standard recovery procedures and equipment. Use a filter-drier when charging the system with recovered refrigerant.



#### **CAUTION**

**Do not loosen any refrigeration or electrical connections before relieving pressure.**



#### NOTE

*Release of refrigerant to the atmosphere is harmful to the environment. Refrigerant must be recycled or discarded in accordance with federal, state, and local regulations.*

4. Disconnect refrigerant lines, pressure switch capillaries, and all electrical connections.
5. Remove failed compressor.



#### CAUTION

**In three phase models with scroll compressors, record compressor motor connections when removing failed compressor. A scroll compressor must rotate in the proper direction. Wire the replacement compressor motor the same way to maintain proper rotation direction.**

6. Install replacement compressor and make all connections.
7. Pressurize and leak test the system at approximately 150 PSI (1034 kPa) pressure.
8. Follow manufacturer's instructions for clean out kits.
9. Connect a vacuum pump to both sides of the system through properly sized connections. Evacuate the system twice to 1500 microns, and the third time to 500 microns. Break the vacuum each time with dry nitrogen to 2 PSI (13.8 kPa).
10. Charge the system with refrigerant (R-22) based on requirements of the evaporator, condensing unit, and lines. Refer to the unit nameplate.
11. Apply power and operate the system. Check for proper operation.

## 4.2 Chilled Fluid Pump

### 4.2.1 Pump Differential Pressure

Refer to chart below. Pump differential pressure must be above minimum PSI to prevent overloading and subsequent motor protector tripping. Measure the pump suction and discharge pressures at the 1/4" flare fittings on the pump piping. The differential is the difference between these two pressures. If the differential pressure is too low, then check pump suction pressure and check system is filled with fluid. Check pump is not air-locked.

### 4.2.2 Pump Suction Pressure

Pump suction pressure must be at least 0 psig (14.7 psia). Measure. If too low, check system is filled and check that pump suction line valve is open.

**Table 6 Pump Suction Pressure**

Model	Pump	Minimum Pressure Differential
PS048, 60	1.0 HP	43 PSI (296 kPa)
PS018, 24, 36	.75 HP	35 PSI (241 kPa)

## 4.3 Refrigerant Gauges

The optional gauges display suction and discharge pressures. They are located in the unit exterior panels, next to the field wiring connections. Refer to **Figure 2**.

---

To replace the gauges, follow proper maintenance procedures. There is a schrader valve on the 1/4 in. flare connection on the piping at the capillary tube connection. Remove the capillary tube at the pipe end to minimize release of refrigerant. Use the capillary tube with the new gauge.

#### **4.4 Reservoir Heater**

The optional reservoir heater maintains the reservoir coolant fluid temperature during the unit off cycle to improve low ambient temperature start-ups. The heater is located low in the reservoir, and is accessed through the louvered panel.

If the heater needs to be replaced, drain the system first. Then have a container to catch the remaining fluid that will come out through the heater fitting.

#### **4.5 Reservoir Tank**

The coolant reservoir tank provides a volume of coolant to reduce temperature fluctuations and a volume of air to allow for expansion of the coolant. The systems engineer who designs the installation must confirm whether or not the coolant and air volumes are suitable for each application, and may decide to add additional fluid storage tanks, expansion tanks, or air vents.

The fluid should typically be at the level of the sightglass in the coolant reservoir tank. Periodic maintenance should include checking the fluid level, and checking for any leaks in the system. If the system is opened to access or replace a piping component, then the fluid level must be checked and may need to be adjusted.

---

## 4A.0 8- AND 10-TON PROCESS CHILLER USER MANUAL SUPPLEMENT

---

### 4A.1 Product Description

The 8- and 10-ton process chiller is a self-contained air cooled system, containing two (2) scroll compressors and two (2) heat exchangers. An optional 2 HP multistage stainless steel pump may be included (see model number) to overcome the high pressure drop found in some MRI and CT systems.

#### 4A.1.1 Additional Equipment

The chiller includes a panel of gauges attached to the end of the cabinet. Eight (8) gauges are included:

- Suction Pressure Refrigerant Circuit #1
- Suction Pressure Refrigerant Circuit #2
- Discharge Pressure Refrigerant Circuit #1
- Discharge Pressure Refrigerant Circuit #2
- Water Inlet Pressure
- Water Outlet Pressure
- Water Inlet Temperature
- Water Outlet Temperature

**Refrigerant Charge:** 29.4 # per circuit R-22

**Internal Glycol Volume (without 100 gallon storage tank):**

12.4 gallons (8-ton, model PS096A)

12.6 gallons (10-ton, model PS120A)

#### Multistage Circulating Pump

The model number indication for the multistage pump is an “M” or “R” in the ninth character of the model number. For example PS096A-AM40.



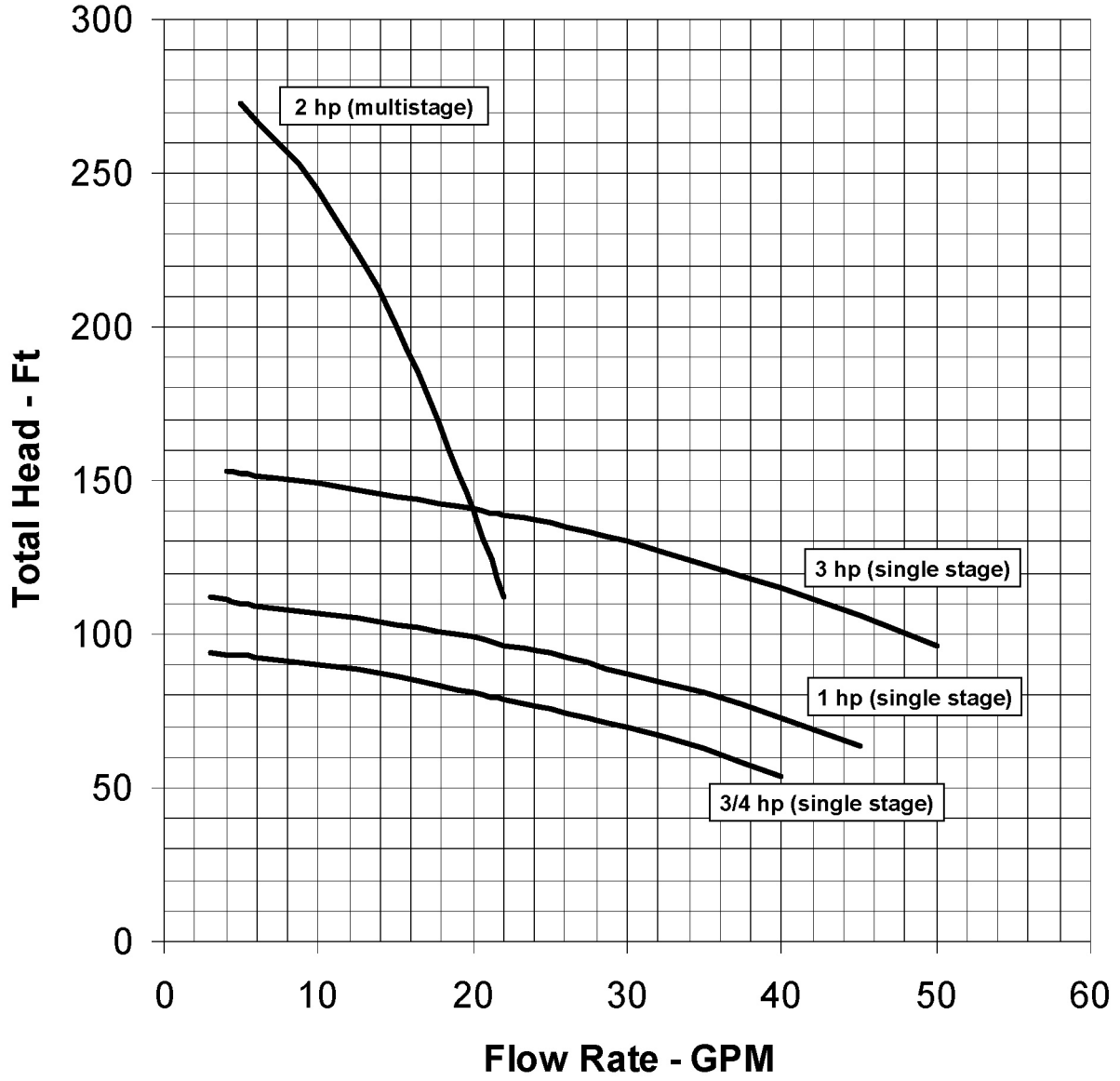
#### NOTE

*The chiller includes a factory-installed and wired multistage circulating pump. It is important that the pump be properly primed before operating.*

1. Fully unscrew the pin located in the drain plug.
2. Close the discharge valve.
3. Remove the vent plug and fully unscrew the drain plug pin.
4. Open the suction valve until liquid flows out of the vent plug connection.
5. Install and torque the vent plugs to 15 lbs-ft. Close the drain plug pin and open the discharge valve.

For additional information, refer to the pump user manual that is shipped with the chiller and attached to the pump with a cable tie. **Figure 3A** shows the flow and pressure characteristics.

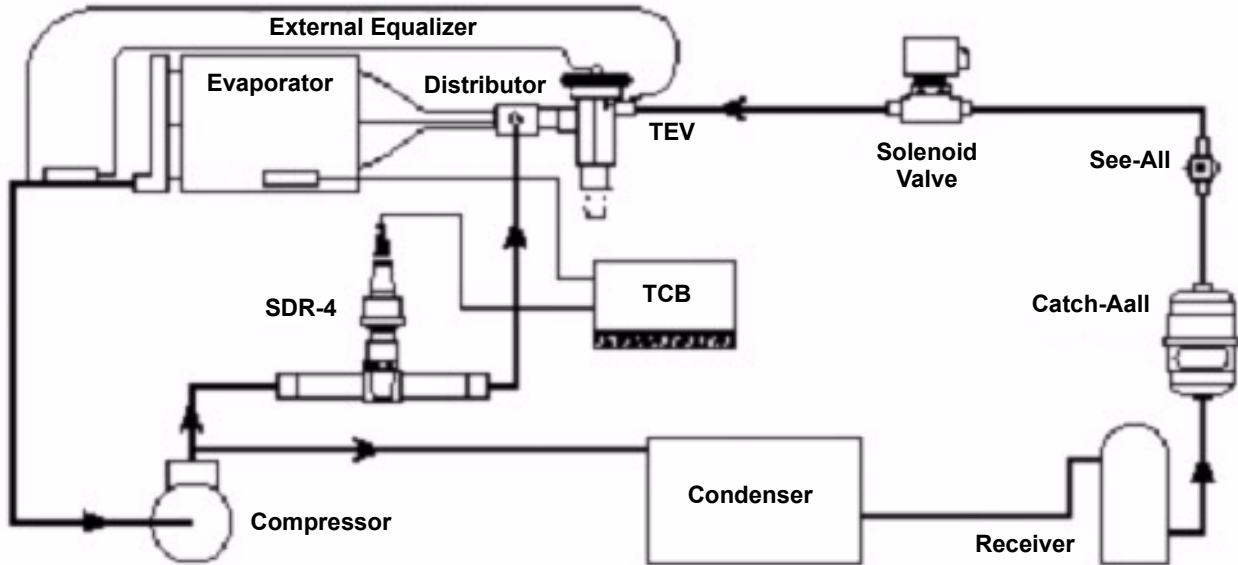
Figure 3A —Process chiller pump performance, 60 Hz



## 4A.2 Temperature Control for 8- and 10-Ton Process Chiller

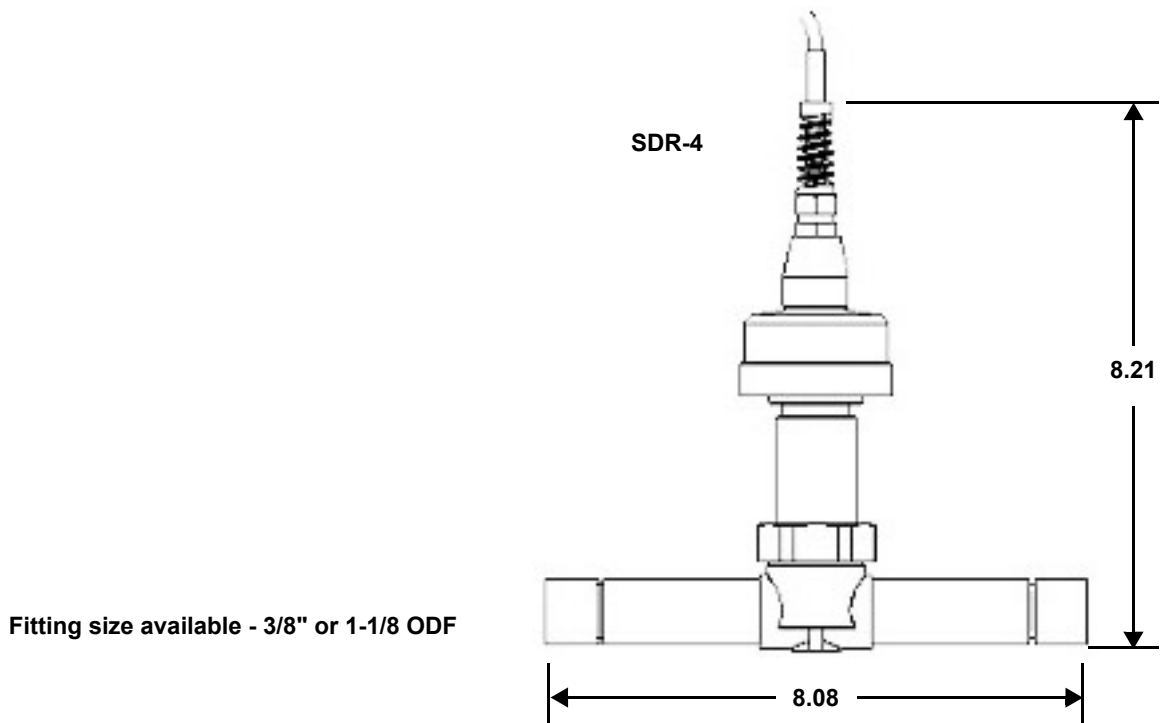
Liebert 8- and 10-ton process chillers include a Sporlan Electronic Hot Gas Bypass Valve and controller. This control provides a precise method of capacity control by bypassing hot gas to the evaporator inlet. **Figure 3B** shows a schematic representation of this piping system.

**Figure 3B** Piping bypass to evaporator inlet

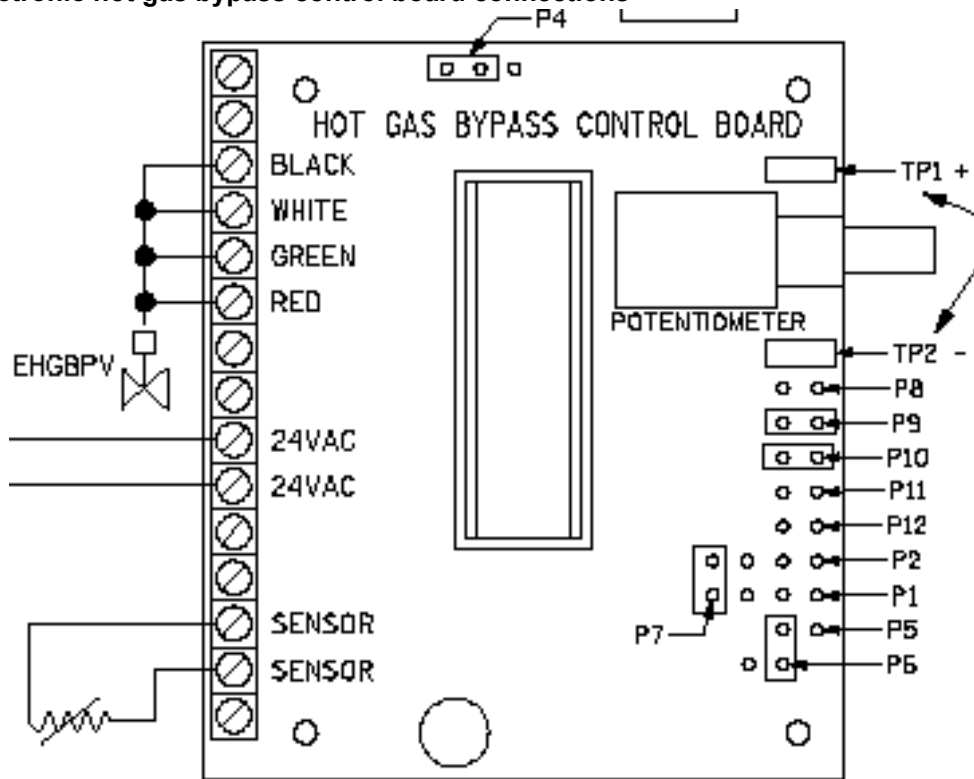


The system is factory-piped and wired. **Figure 3C** shows the connections to the control board.

**Figure 3C** Electronic hot gas bypass valve



**Figure 3D Electronic hot gas bypass control board connections**



The sensor, 24 VAC power, and the electronic valve are factory-wired to the control board. Jumpers are factory-set to the following pins:

- P7—Temperature sensor enable selector
- P9—“Close on rise” logic selector
- P12—Valve selector

In addition a jumper can be field installed on the following pins to troubleshoot operation of the valve:

- P5—Force valve open: valve opens and remains open as long as jumper is installed
- P6—Force valve closed: valve closes and remains closed as long as jumper is installed



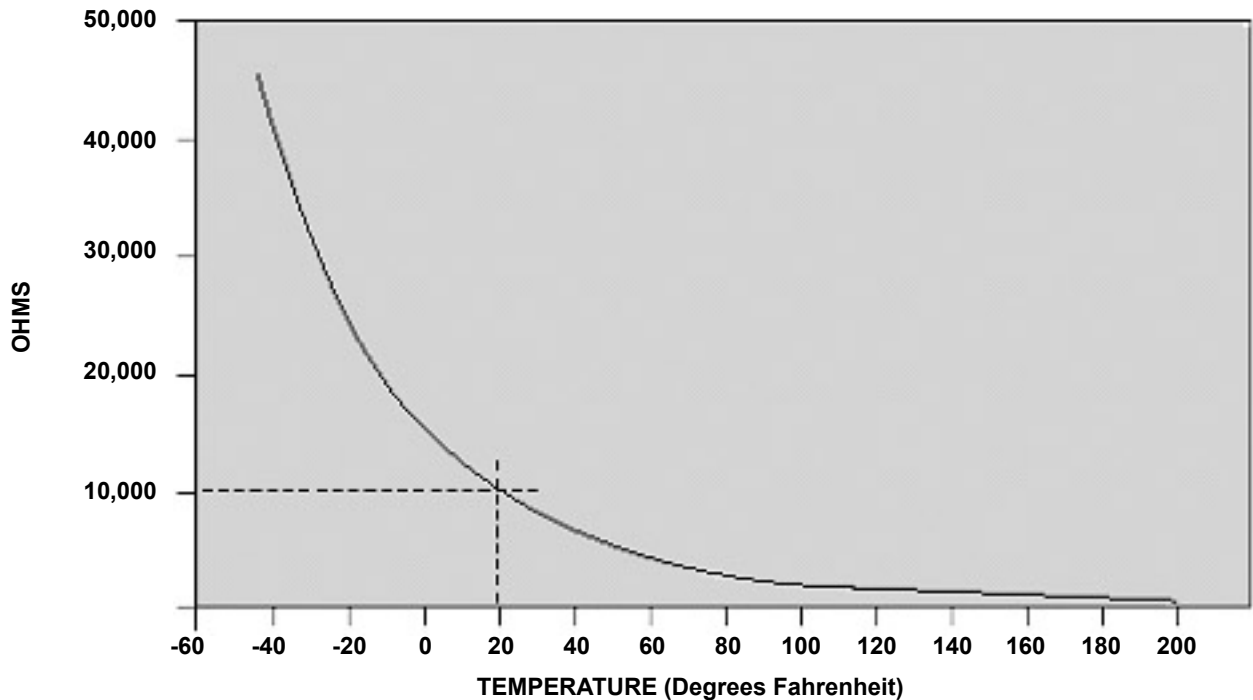
---

### 4A.3 Temperature Setpoint for Chiller

The temperature setpoint for the chiller should be set by turning the potentiometer. To obtain an accurate setpoint, connect a voltmeter (millivolt) to TP1 and TP2. The readout will display temperature in degrees Fahrenheit. Turn the potentiometer to the desired setpoint.

A “well” sensor is factory-piped and wired to accurately measure the temperature of the water leaving the chiller. This sensor provides input to the Electronic Hot Gas Bypass Controller. The sensor changes electrical resistance in response to temperature changes. To check or troubleshoot the sensor, disconnect it from the controller and measure the resistance. **Figure 3E** shows the relationship between temperature and resistance.

**Figure 3E** Temperature sensor resistance



### 4A.4 Flow Control

A circuit setter is factory-installed in the supply line and a ball valve is factory-installed in a bypass loop. The desired system flow to the load should be set by adjusting the circuit setter to the required flow rate. If a flow rate of less than 5 gpm is required, the ball valve should be adjusted to keep the overall system flow rate up. If low suction pressures are present, the circuit setter should be set to a higher flow, with the bypass valve used to control flow to the load.

## 5.0 TROUBLESHOOTING

Use this section to assist in troubleshooting your unit. Tables are grouped by product function for convenience.



### WARNING

**ONLY QUALIFIED PERSONNEL SHOULD PERFORM SERVICE ON THESE UNITS. LETHAL VOLTAGE IS PRESENT IN SOME CIRCUITS. USE CAUTION WHEN TROUBLESHOOTING WITH POWER ON. DISCONNECT AND LOCK OUT POWER BEFORE REPLACING COMPONENTS. USE CAUTION AND STANDARD PROCEDURES WHEN WORKING WITH PRESSURIZED PIPES AND TUBES.**



### CAUTION

**When using jumpers for troubleshooting, always remove jumpers when maintenance is complete. Jumpers left connected could override controls and cause equipment damage.**

**Table 7 Chilled Fluid Pump Troubleshooting**

Symptom	Possible Cause	Check or Remedy
Will not start	No main power	Check L1, L2 (and L3) for rated voltage.
	Overloads tripped	Push reset button on pump overload. Check amp draw.
	No output voltage from transformer	Check for 24 VAC between 3 and 37. If no voltage, check primary voltage.
	Transformer circuit breaker tripped	Check for 24 VAC between 3 and 37. If no voltage, check for short and reset breaker.
Noisy operation	Worn motor bearings	Replace pump.
	Low discharge head	Throttle discharge - improve suction conditions.
	Cavitating pumps	Adjust system pressures.
	Debris lodged in impeller	Remove cover and clean out.
Trips overload relay	Loose electrical connections	Tighten connections.
	Incorrect overload relay or must trip amp setting too low	Replace with correct overload relay.
	Pump motor defective	Check for motor winding short or ground.
	Low line voltage	Check line voltage and determine location of voltage drop.
	Single phasing	Check voltage across all 3 legs at contactor. Correct source of problem. (3-phase units only)
Running hot	Clogged bypass orifice	See Symptom: Trips overload relay. Remove orifice unions, check screen.

**Table 8 Compressor Troubleshooting**

Symptom	Possible Cause	Check or Remedy
Will not start	Contactors not pulling in	(Also see Fan) Compressor controlled by same contactor as Fan.
	No main power	Check L1, L2 (and L3) for rated voltage.
	No output voltage from transformer	Check for 24 VAC between 3 and 37. If no voltage, check primary voltage.
	Transformer circuit breaker tripped	Check for 24 VAC between 3 and 37. If no voltage, check for short and reset breaker.
	Solenoid valve not energizing	Hold screwdriver over solenoid and check for magnetic field. This indicates solenoid is energized.
	Low pressure switch not making contact	Check gas pressure—manually energize low pressure switch.
	High pressure switch open	Reset switch. Refer to other refrigeration troubleshooting suggestions.
	Loose electrical connections	Tighten connections.
	Compressor motor burned out	Check and replace compressor if defective.
	Short cycle prevention control	
Low discharge pressure	Insufficient refrigerant in system	Check for leaks, repair, and add refrigerant.
	Worn piston rings/valves	Replace compressor.
Noisy operation	Slugging due to floodback of refrigerant	See Symptom: Flooding (Refrigeration System).
	Broken connecting rods, valves, or other running gear	Replace compressor.
Low suction pressure	Insufficient refrigerant in system	Check for leaks, repair, and add refrigerant.
	Plugged filter-drier	Replace filter.
Compressor motor protectors tripping or cycling	High suction temperature	Reduce suction temperature by TEV adjustment or provide desuperheating.
	Compressor motor defective	Check for motor winding short or ground.
	Loose electrical connections	Tighten connections.

**Table 8 Compressor Troubleshooting**

Symptom	Possible Cause	Check or Remedy
Compressor cycles intermittently	Low pressure switch erratic in operation	Check tubing to switch to see if clogged or crimped. Check setting of switch.
	Insufficient refrigerant in system	Check for leaks, repair, and add refrigerant.
	Air in system	Purge.
Compressor cycles on locked rotor	Compressor motor defective	Check for motor winding short or ground.
	Low line voltage	Check line voltage and determine location of voltage drop.
	Single phasing	Check voltage across all 3 legs at contactor. Correct source of problem. (3-phase units only)
Will not pump down	Broken connecting rods or pistons	Replace compressor.
	Leaking liquid line solenoid valve or dirt in valve	Replace valve if clean; clean out valve if dirty.
Running hot	Compression ratio too high	Check setting of high and low pressure switches. Check condenser—is it plugged? Check that condenser fan is operating properly.
	Excessive blow-by into crankcase—worn rings or valves	Replace compressor. See Symptom: Compressor cycles on locked rotor.

**Table 9 Refrigeration System Troubleshooting**

Symptom	Possible Cause	Check or Remedy
Low suction pressure; High superheat	Insufficient refrigerant in system	Check for leaks, repair, and add refrigerant.
	Plugged filter-drier	Replace filter.
	Improper superheat adjustment	Reset expansion valve for 10 to 15°F superheat.
	Defective expansion valve sensing element	Replace element.
	Restricted external equalizer	Liquid indicator.
High suction pressure; Low superheat	Plugged filter-drier	Replace filter.
	Improper superheat adjustment	Reset expansion valve for 10 to 15°F superheat.
	Restricted external equalizer	Liquid indicator.
	TEV seat leak	Check valve for leaks.
Low suction pressure; Low superheat	Evaporator oil logged	Increase HGBP setpoint.
High discharge pressure	Dirty condenser or drycooler fins	Clean coil.
	Condenser fan not operating	Check fan operation.
	High refrigerant charge	Check refrigerant charge.
	Hot gas bypass valve adjusted improperly	Adjust properly.
	Insufficient air flow across condenser coil	Remove debris from coil and air inlets.
Low discharge pressure	Faulty head pressure control valve or condenser fan speed control	Replace if defective.
	Worn piston rings/valves	Replace compressor.
Flooding	Defective or improperly set expansion valve	Increase superheat or replace valve.
	Low condensing pressure	Check head pressure control device.

**Table 10 Condenser Fan Troubleshooting**

Symptom	Possible Cause	Check or Remedy
Will not start	Contactors not pulling in	(Also see Compressor) Fan controlled by same contactor as Compressor.
	No main power	Check L1, L2 (and L3) for rated voltage.
	No output voltage from transformer	Check for 24 VAC between 3 and 37. If no voltage, check primary voltage.
	Transformer circuit breaker tripped	Check for 24 VAC between 3 and 37. If no voltage, check for short and reset breaker.
	Fan motor capacitor defective	Check capacitor.
Trips internal motor protector	Fan motor defective	Check for motor winding short or ground.
Noisy operation	Fan blade loose	Check/tighten set screws on fanblade hub.
	Worn motor bearings	Replace motor.
	Fanblade not rotating freely	Check for debris in fanblade path. Check for rubbing on fan housing.

---

## 6.0 SEMI-ANNUAL MAINTENANCE INSPECTION CHECKLIST

---

### Liebert Process Fluid Chiller

Date: \_\_\_\_\_

Prepared by: \_\_\_\_\_

Model #: \_\_\_\_\_

Serial #: \_\_\_\_\_

#### Air Cooled Condenser

- 1. Condenser coil clean
- 2. Motor mounts tight
- 3. Bearings in good condition

#### Chilled Water Pump

- 1. Check for leaks
- 2. Check pump operation

#### Compressor

- 1. Check for leaks

#### Electrical Panel

- 1. Check electrical connections
- 2. Check operation sequence and cycling

#### Refrigeration Cycle/Section

- 1. Check refrigerant lines
- 2. Check for moisture (sight glass)
- 3. Check suction pressure
- 4. Check head pressure
- 5. Check discharge pressure
- 6. Check hot gas bypass valve
- 7. Check thermostatic exp valve
- 8. Check superheat

#### Notes:

Signature: \_\_\_\_\_

Make photocopies of this form for your records

## 7.0 PARTS



### NOTE

The numbers in the FN column in the following tables refer to the figures at the end of this section. For example, FN 1-3 indicates Figure 1, part number 3.

### 7.1 Parts List

**Table 11 Fans and Motors**

		Model Numbers										
		Capacity	1.5 Ton		2 Ton		3 Ton		4 Ton		5 Ton	
		Hz	60	50	60	50	60	50	60	50	60	50
FN	Description	Part No.	018	021	024	028	036	038	048	047	060	059
1-1	Fan Blade	1C21119P1	1	1								
		1D21122P1			1	1						
		1C21120P1					1	1				
		127914P1							1	1	1	1
1-2	Motor 208/230V	1D21121P1	1									
	Motor 200/208/230V	1D21122P1			1		1	1				
	Motor 380/420/460V	1D21122P2			1		1	1				
	Motor 200/208/230V	127902P1		1		1			1	1	1	1
	Motor 380/420/460V	127902P2							1	1	1	1

**Table 12 Compressor and Refrigerant Valves**

		Model Numbers										
		Capacity	1.5 Ton		2Ton		3Ton		4Ton		5 Ton	
		Hz	60	50	60	50	60	50	60	50	60	50
FN	Description	Part No.	018	021	024	028	036	038	048	047	060	059
Compressor												
1-3	208/230V, 1 Phase	146300P1	1									
	208/230V, 1 Phase	146303P1			1							
	200/208/230V, 1 Phase	1D21116P1				1	1					
	208/230V, 3 Phase	1D21116P2					1					
	380/420/460V, 3 Phase	129102P2					1	1				
	208/230V, 3 Phase	138980P2							1			
	460V, 3 Phase	138980P1							1			
	200/208/230V, 3 Phase	127650P1									1	1
	200/230, 1 Phase	1C19511P1		1								
	200/230V, 1 Phase	130913P2						1				
	208/230V, 3 Phase	129102P1						1				
	208/230V, 3 Phase	132082P1								1		
	380/420V, 3 Phase	132082P2								1		
380/420/460V, 3 Phase	127650P2									1	1	
Crankcase Heater												
	All Voltages	1C21138P2	1	1	1							
		1C21138P1				1	1	1	1		1	

**Table 12 Compressor and Refrigerant Valves**

		Model Numbers										
		Capacity	1.5 Ton		2Ton		3Ton		4Ton		5 Ton	
		Hz	60	50	60	50	60	50	60	50	60	50
FN	Description	Part No.	018	021	024	028	036	038	048	047	060	059
	380/420V	1C21138P2								1		1
	200/230V	1C21138P1								1		1
Pressure Switches												
High Pressure Switch												
	All Voltages	1C21139P1	1	1	1	1						
	208/230V	1C21139P1					1					
	200/230V, 1 Phase	1C21139P1						1				
	All Voltages	127938P2							1	1	1	1
	200/230V, 3 Phase	127938P2						1				
	460V	127938P2					1					
	380/420V	127938P2						1				
Low Pressure Switch		P-3070	1	1	1	1	1	1	1	1	1	1
Refrigerant Valves												
	HGBP Valve	P-0180	1	1	1	1	1	1				
	HGBP Solenoid	P-0070	1	1	1	1						
	HGBP Solenoid	P-0080					1	1				
	HGBP Valve	P-018A							1	1	1	1
	HGBP Solenoid	P-287A							1	1	1	1
	Thermal Expansion Valve	140201P1	1	1	1	1						
		140201P3					1	1				
		140201P4							1	1	1	1
	Liquid Line Solenoid Valve	126630P1	1	1	1	1						
		127935P5					1	1				
		127935P1							1	1	1	1
	Sight Glass	1A21133P1	1	1								
		P-3870			1	1	1	1				
		P-0050							1	1	1	1
	Filter Dryer	1C21132P1	1	1								
		P03-0030			1	1	1	1				
		128177P1							1	1	1	1
Condenser Coils												
1-5	Condenser Coil	1021107P1	1	1								
		1D21106P1			1	1						
		1D21108P1					1	1				
		127900P1							1	1	1	1



**Table 12 Compressor and Refrigerant Valves**

		Model Numbers										
		Capacity	1.5 Ton		2Ton		3Ton		4Ton		5 Ton	
		Hz	60	50	60	50	60	50	60	50	60	50
FN	Description	Part No.	018	021	024	028	036	038	048	047	060	059
Lee-Temp Parts												
	Head Pressure Control Valve	1C21207P1	1	1	1	1	1	1				
		127956P1							1	1	1	1
1-4	Receiver	127130P1	1	1								
		127130P2			1	1						
		127130P3					1	1				
		127130P5							1	1	1	1
	Pressure Switch	127972P1	1	1	1	1	1	1	1	1	1	1
	Check Valve	W-0092	1	1	1	1	1	1				
		W-0091							1	1	1	1
	Relief Valve	127140P1	1	1	1	1	1	1	1	1	1	1

**Table 13 Quick Disconnect Couplings**

FN	Models	Hot Gas		Suction Line		Liquid Line	
		Female	Male	Female	Male	Female	Male
	018 / 021	1C19509P1	1C19509P5	1C19508P6	1C19509P4	1C19508P1	1C19509P6
	024 / 028	1C19509P1	1C19509P5	1C19508P2	1C19509P1	1C19508P1	1C19509P5
	036 / 038	1C19508P6	1C19509P4	1C19508P2	1C19509P2	1C19508P1	1C19509P5
	048 / 047	1C19508P2	1C19509P1	1C19508P7	1C19509P8	1C19508P6	1C19509P4
	060 / 059	1C19508P2	1C19509P1	1C19508P7	1C19509P8	1C19508P6	1C19509P4

**Table 14 Fluid Controls**

		Model Numbers										
		Capacity	1.5 Ton		2 Ton		3 Ton		4 Ton		5 Ton	
		Hz	60	50	60	50	60	50	60	50	60	50
FN	Description	Part No.	018	021	024	028	036	038	048	047	060	059
Evaporator and Reservoir												
2-1	Evaporator	140212P1	1	1								
		140212P2			1	1						
		140212P3					1	1				
		140212P4							1	1		
		140212P5									1	1
2-2	Reservoir	140203P1	1	1	1	1						
		140203P2					1	1	1	1	1	1
	Optional Reservoir Heater	140215P1	1	1	1	1	1	1	1	1	1	1
	Relief Valve	P-4730	1	1	1	1	1	1	1	1	1	1

**Table 14 Fluid Controls**

		Model Numbers										
		Capacity	1.5 Ton		2 Ton		3 Ton		4 Ton		5 Ton	
		Hz	60	50	60	50	60	50	60	50	60	50
FN	Description	Part No.	018	021	024	028	036	038	048	047	060	059
Circulating Pump and Valves												
1-3	Pump - 60 Hz, Iron	140205P1	1		1		1					
		140205P1							1		1	
	Pump - 60 Hz, SS	140204P1	1		1		1					
		140204P2							1		1	
	Pump - 50 Hz, Iron	140255P1		1		1		1				
		140255P1								1		1
	Pump - 50 Hz, SS	140254P1		1		1		1				
		140254P2								1		1
	Ball Valve	1C14431P1	2	2	2	2						
		1C14431P2					2	2	2	2	2	2
	Fluid Relief Valve	P-4730	1	1	1	1	1	1	1	1	1	1

**Table 15 Electrical Panels**

		Model Numbers										
		Capacity	1.5 Ton		2 Ton		3 Ton		4 Ton		5 Ton	
		Hz	60	50	60	50	60	50	60	50	60	50
FN	Description	Part No.	018	021	024	028	036	038	048	047	060	059
Condenser Electric Panel												
4-1	Contactora - 1 Phase	E-011B	1	1	1	1	1	1				
	Contactora - 3 Phase	E-009F					1	1	1	1	1	1
4-2	Fan Capacitor	B-1220	1	1	1	1	1	1				
		B03-0030							1	1	1	1
	Comp. Start Cap. - 1 Phase	127194P1	1	1	1	1	1	1				
	Comp. Run Cap. - 1 Phase	C03-005A	1	1	1	1	1	1				
4-3	Transformer - 380/415V	127937P3						1		1		1
	Transformer - 460V	127937P1					1		1		1	
4-4	Fuse- 380/415/460V	127977P1					1	1	1	1	1	1
	Fuse Holder- 380/415/460V	4A10033P1					1	1	1	1	1	1
Chiller Electric Panel												
3-1	Contactora - 1 Phase		1	1	1	1	1	1				
	Contactora - 3 Phase						1	1	1	1	1	1

**Table 15 Electrical Panels**

		Model Numbers										
		Capacity	1.5 Ton		2 Ton		3 Ton		4 Ton		5 Ton	
		Hz	60	50	60	50	60	50	60	50	60	50
FN	Description	Part No.	018	021	024	028	036	038	048	047	060	059
3-2	Power Block - 1 Phase		1	1	1	1	1	1				
	Power Block - S Phase						1	1	1	1	1	1
3-3	T1 Transformer- 208/230V		1		1		1		1		1	
	T1 Transformer - 200/230V			1		1		1		1		1
	T1 Transformer - 460V		1		1		1		1		1	
	T1 Transformer - 315/415V			1		1		1		1		1
3-4	Overload Relay		1	1	1	1	1	1	1	1	1	1
	Overload Cover		1	1	1	1	1	1	1	1	1	1
3-5	PSK Relay		1	1	1	1	1	1	1	1	1	1
3-6	AR Relay		1	1	1	1	1	1	1	1	1	1

**Table 16 Exterior Panels**

		Model Numbers										
		Capacity	1.5 Ton		2 Ton		3 Ton		4 Ton		5 Ton	
		Hz	60	50	60	50	60	50	60	50	60	50
FN	Description	Part No.	018	021	024	028	036	038	048	047	060	059
<b>Chiller Exterior Panels</b>												
5-1	Exterior Left	140101P1	1	1	1	1						
5-2	Exterior Right	140104P1	1	1	1	1						
5-3	Front Access	121694P1	1	1	1	1						
5-4	Cover Top	140135P1	1	1	1	1						
5-5	Exterior Rear	140107P1	1	1	1	1						
5-6	Lowered	140118G1	1	1	1	1						
5-1	Exterior Left	140102P1					1	1				
5-2	Exterior Right	140105P1					1	1				
13	Front Access	121701P1					1	1				
5-4	Cover Top	140136P1					1	1				
5-5	Exterior Rear	140108P1					1	1				
5-6	Louvered	140119G1					1	1				
5-1	Exterior Left	140103P1							1	1	1	1
5-2	Exterior	140106P1							1	1	1	1
5-3	Front Access	121913P1							1	1	1	1
5-4	Cover Top	140137P1							1	1	1	1
5-5	Exterior Rear	140109P1							1	1	1	1
5-6	Louvered	140120G1							1	1	1	1
5-7	Gauge Hole Cover	140138P1	1	1	1	1	1	1	1	1	1	1

**Table 16 Exterior Panels**

		Model Numbers										
		Capacity	1.5 Ton		2 Ton		3 Ton		4 Ton		5 Ton	
		Hz	60	50	60	50	60	50	60	50	60	50
<b>FN</b>	<b>Description</b>	<b>Part No.</b>	<b>018</b>	<b>021</b>	<b>024</b>	<b>028</b>	<b>036</b>	<b>038</b>	<b>048</b>	<b>047</b>	<b>060</b>	<b>059</b>
Condenser Exterior Panels												
6-1	Front Access	121694P1	1	1	1	1						
6-2	Cover Top	121695P1	1	1	1	1						
6-3	Exterior Left	140127P1	1	1	1	1						
6-4	Exterior Right	121691P1	1	1	1	1						
6-5	Exterior Rear	121699P1	1	1	1	1						
6-6	Outlet Air Grill	1C21128P1	1	1	1	1						
6-1	Front Access	121701P1					1	1				
6-2	Cover Top	121702P1					1	1				
6-3	Exterior Left	140128P1					1	1				
6-4	Exterior Right	121705P1					1	1				
6-5	Exterior Rear	121706P1					1	1				
6-6	Outlet Air Grill	1C21129P1					1	1				
6-1	Front Access	127913P1							1	1	1	1
6-2	Cover Top	127910P1							1	1	1	1
6-3	Exterior Left	140129P1							1	1	1	1
6-4	Exterior Right	127912P1							1	1	1	1
6-5	Exterior Rear	127907P1							1	1	1	1
6-6	Outlet Air Grill	127915P1							1	1	1	1

Figure 1. Condenser Assembly

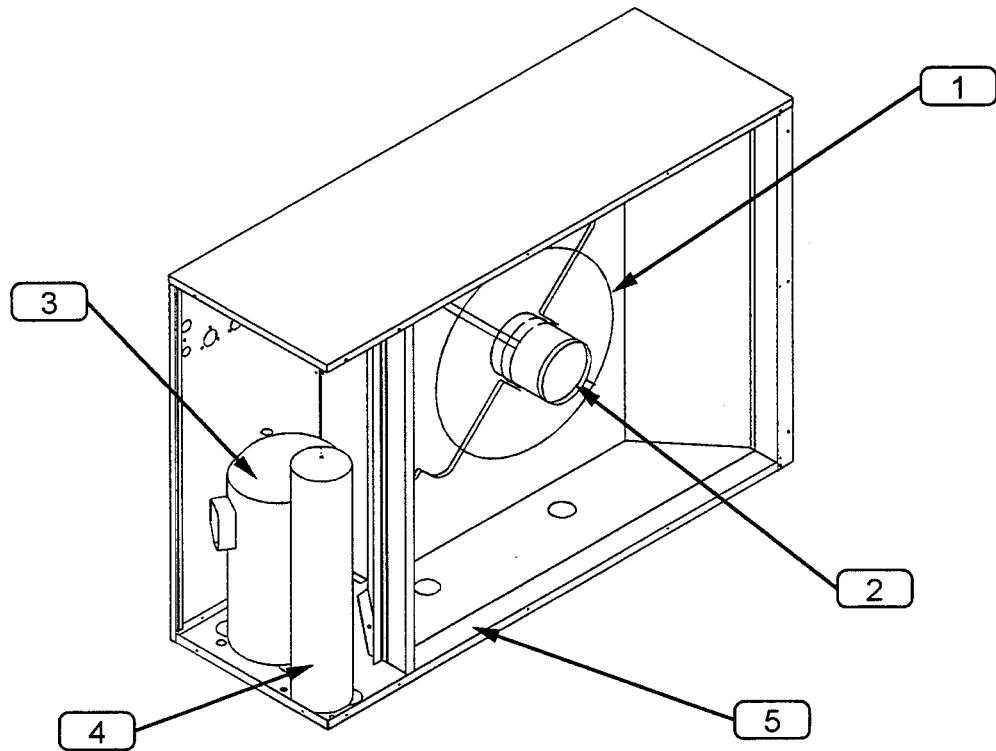


Figure 2. Chiller Assembly

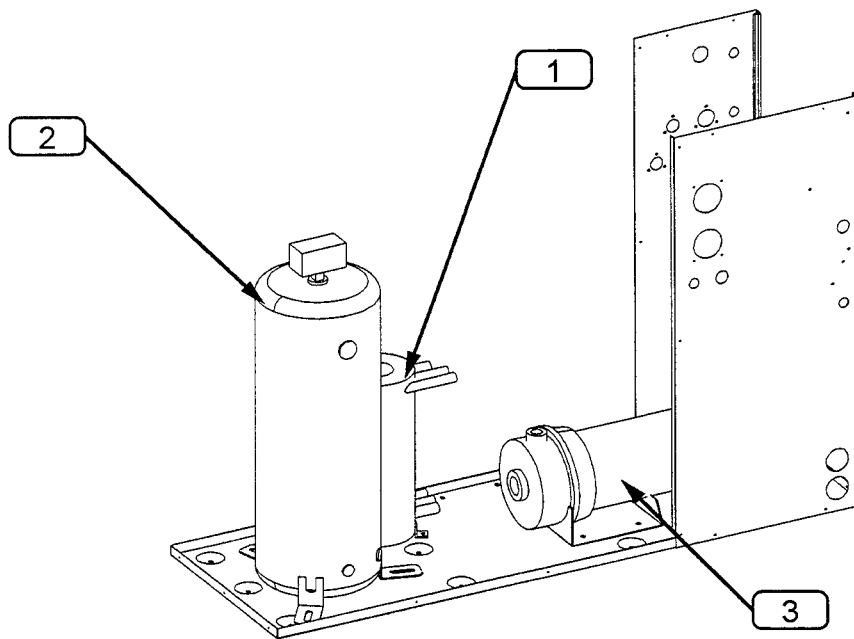


Figure 3. Chiller Electric Panel

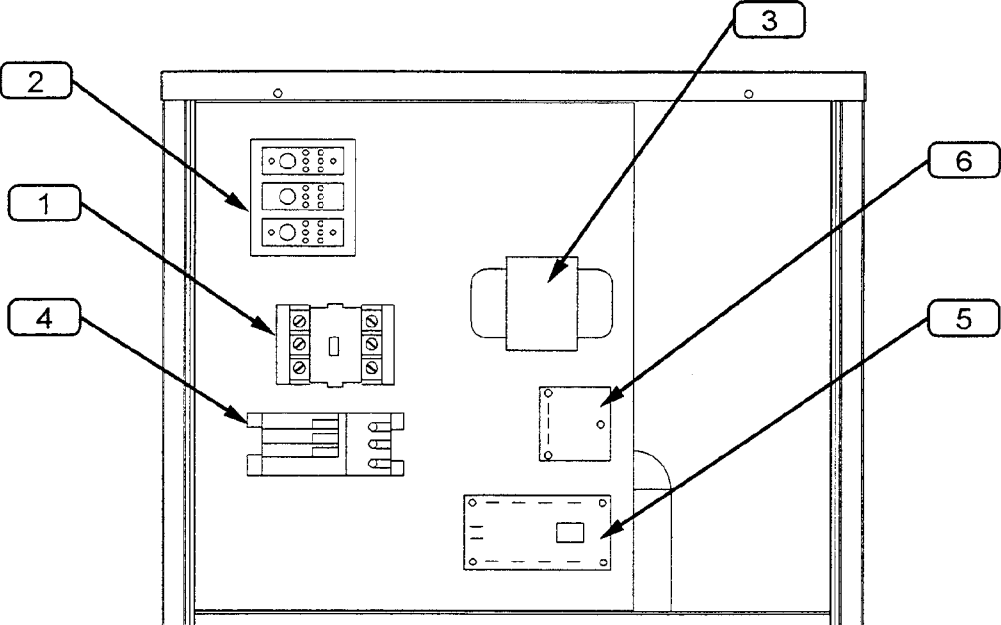


Figure 4. Condenser Electric Panel

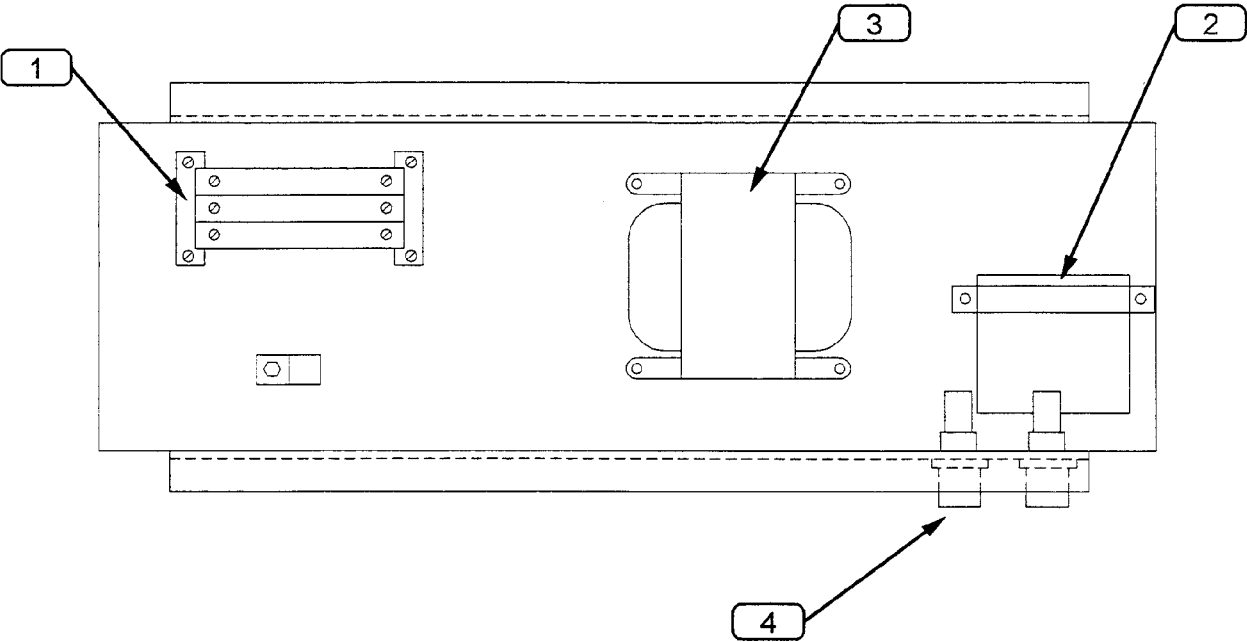


Figure 5. Chiller Exterior Panels

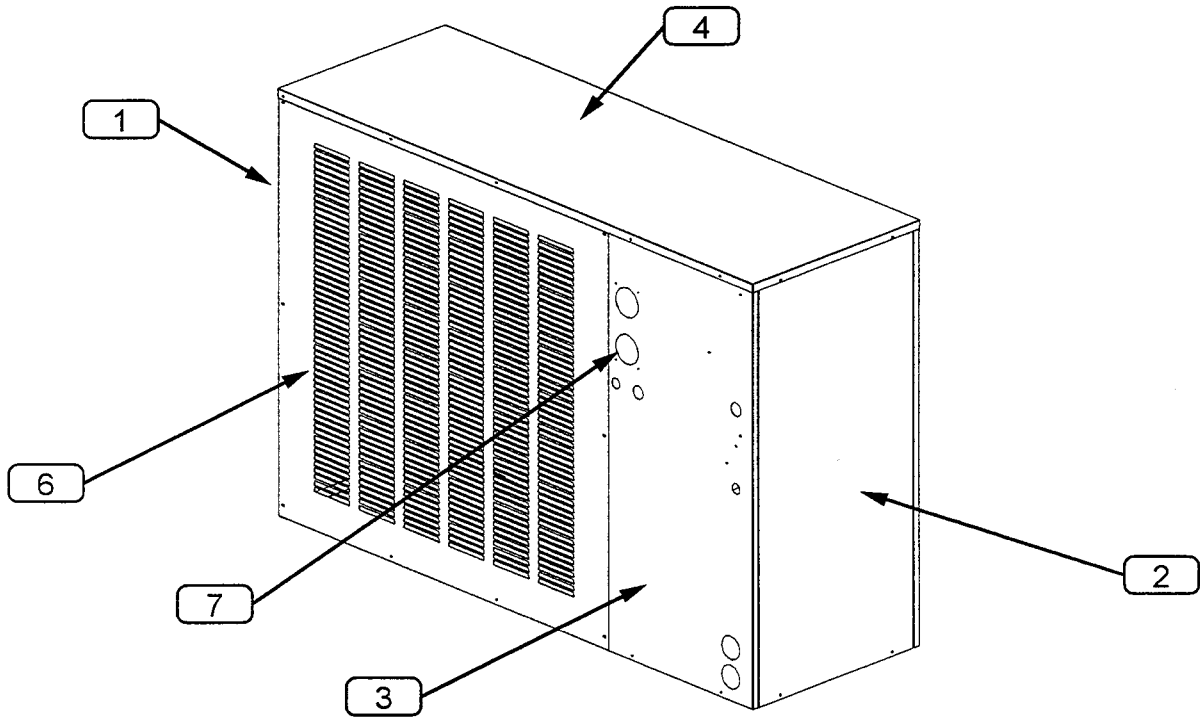
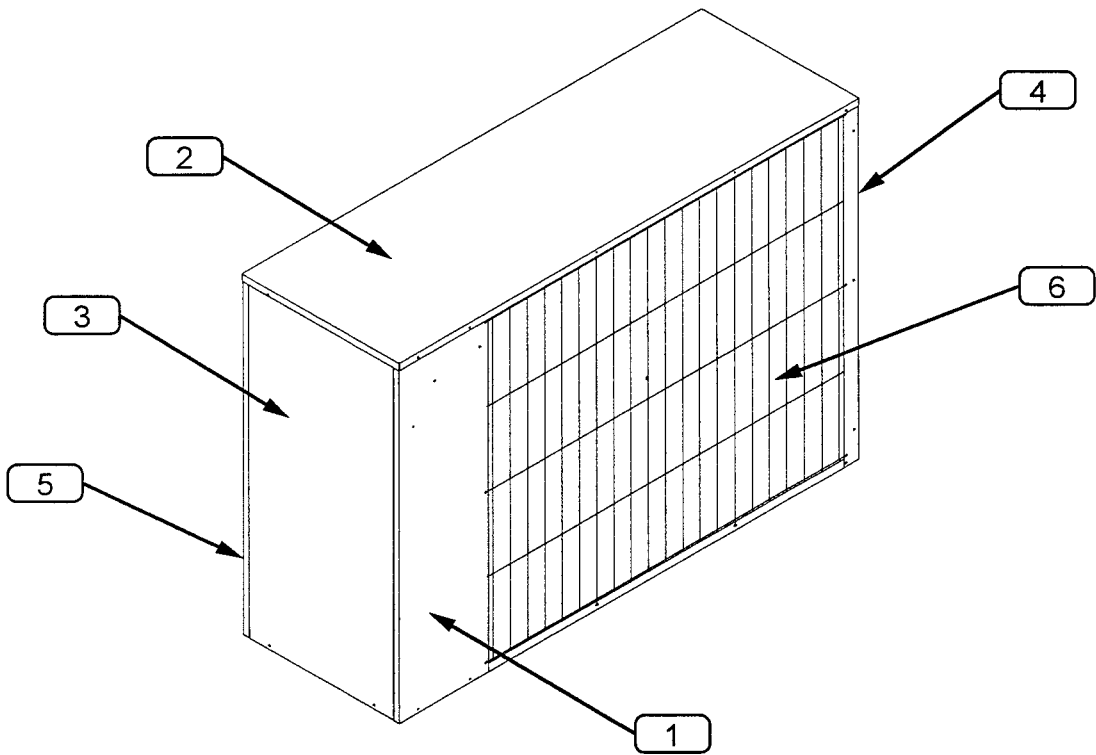


Figure 6. Condenser Exterior Panels



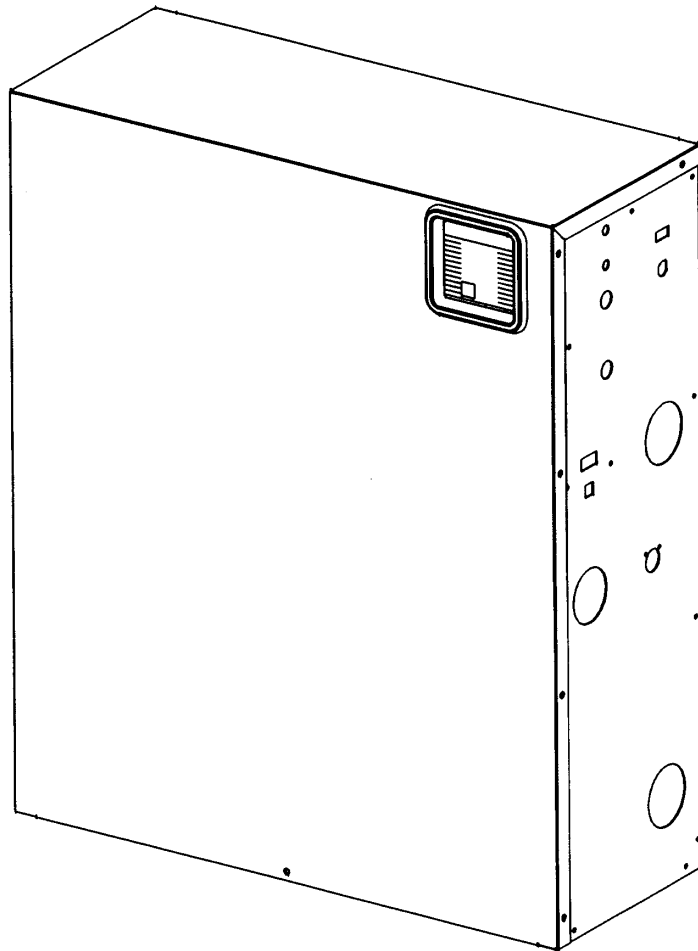
---

## 8.0 APPENDIX A: EMERGENCY WATER SOURCE MODULE

---

This module is a pre-piped and wired assembly which consists of an almond colored, powder coated and baked enclosure, RCM4 monitor, adjustable time delay relays, now switch high temperature thermostat, solenoid valves, ball valves on the entering and leaving lines connected to the chiller, a fluid pressure gage and valve, and a digital display of supply fluid temperature. It also includes a ball valve and double check backflow preventer on the entering “city water” line. The module has a local display for high fluid temperature, loss of fluid flow, and emergency water on. It also has a non-powered common alarm contact. It requires a 120-volt single-phase power input. This module is for use on systems that circulate water as the cooling medium (it is not for use with glycol systems). It automatically switches to emergency water on a high fluid alarm, or a loss of fluid now alarm.

**Figure 4 The Emergency Water Source Module**



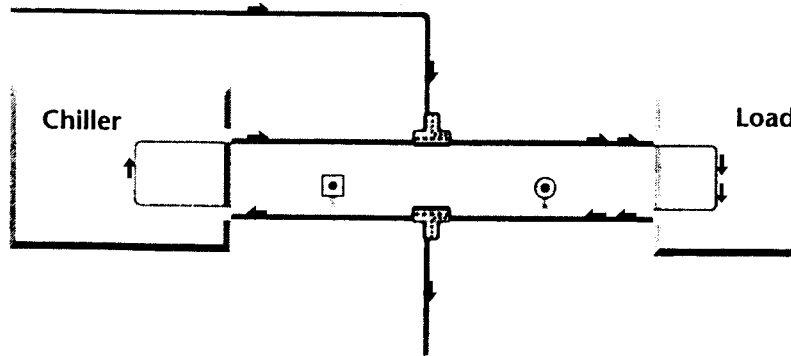


## 8.1 Model Numbers

EWS05W-K00	for application with 1.5 and 2 ton Process Chillers
EWS10W-K00	for application with 3, 4 and 5 ton Process Chillers

## 8.2 Typical Application

Figure 5 Emergency Water Bypass



## 8.3 Sequence of Operation

In normal operation mode, cold water flow from the chiller passes across the flow switch, through the energized supply solenoid valve, across the supply temperature sensor, and out to the load. Water from the load passes back through the energized return solenoid valve and out to the chiller. If the flow switch senses loss of flow, or the thermostat senses high water temperature, then a time delay is initiated. This is to prevent nuisance switchovers. After the time delay (see below) switchover occurs to the emergency water source.

### Time Delay Settings (seconds)

Condition	Factory	Minimum	Maximum
Loss of flow	10	0	90
High water temperature	180	0	480

On switchover, the supply and return solenoid valves are de-energized to close and the alternate and drain solenoid valves are energized to open. The RCM4 displays the switchover condition and switches the common alarm contacts. The switchover is “locked in”. Pressing the “reset” button returns the module to normal operation.



#### NOTE

*During normal operation, the auto/manual switch is set to “auto”. The switch can be set to “manual” to force switchover for troubleshooting or maintenance.*



#### NOTE

*The “remote shutdown” function prevents emergency switchover operation, regardless of other controls status.*

## 8.4 System Components

**RCM4 Monitor.** Configured to activate an LED, an audible alarm, and switch the common alarm output contacts in response to a loss of flow or high supply water temperature switchover. The silence/reset button silences the alarm. The button also resets the LED's and contacts if the unit has returned to normal mode. Thermostat monitors supply water temperature. The thermostat (switchover) setpoint is adjustable from -30 to 130° F. The differential (temperature drop required

---

to open the switch) is adjustable from 1 to 30° F. The thermostat includes a digital display mounted on the right side of the module which indicates the supply water temperature, and the setpoint.

**Flow Switch.** Monitors supply water flow. The flow switch setpoint is adjustable; see below.

#### Flow Switch Setpoints (gpm)

Model#	Minimum	Maximum
EWS05W-K00	0.3	1.1
EWS10W-K00	3.7	13.3

**Solenoid Valves.** 24VAC, 2way, pilot or direct operated, with brass body.

**Isolation Valves.** 1/4 turn, brass body ball valves for isolation of piping components in the event of a service necessity.

**Fluid Pressure Gage.** Displays pressure of either the supply or return water line, selectable by a 3way ball valve adjacent to the gage.

**Backflow Preventer.** Double-check design, located at the “city water” (alternate water) piping connection point.

## 8.5 Installation

Prepare the location(s) for the unit. See **Figure 7**. Allow adequate clearance for convenient maintenance. Set unit on the floor or bolt securely to the wall using appropriate anchors (supplied by others).



#### WARNING

**FAILURE TO FASTEN UNIT SECURELY TO WALL STUDS OR STRUCTURAL MEMBERS WITH APPROPRIATE ANCHORS (SUPPLIED BY OTHERS) MAY RESULT IN PRODUCT FAILURE AND HUMAN INJURY.**

Connect the unit piping to the chiller, load, city (alternate) water and drain (or recirculator), as shown in **Figure 6**. Piping connections are also labeled on the unit. Make sure to bleed all air out of the water system. Note that the pressure limit of the Emergency Water Source Module is 100 psig.



#### CAUTION

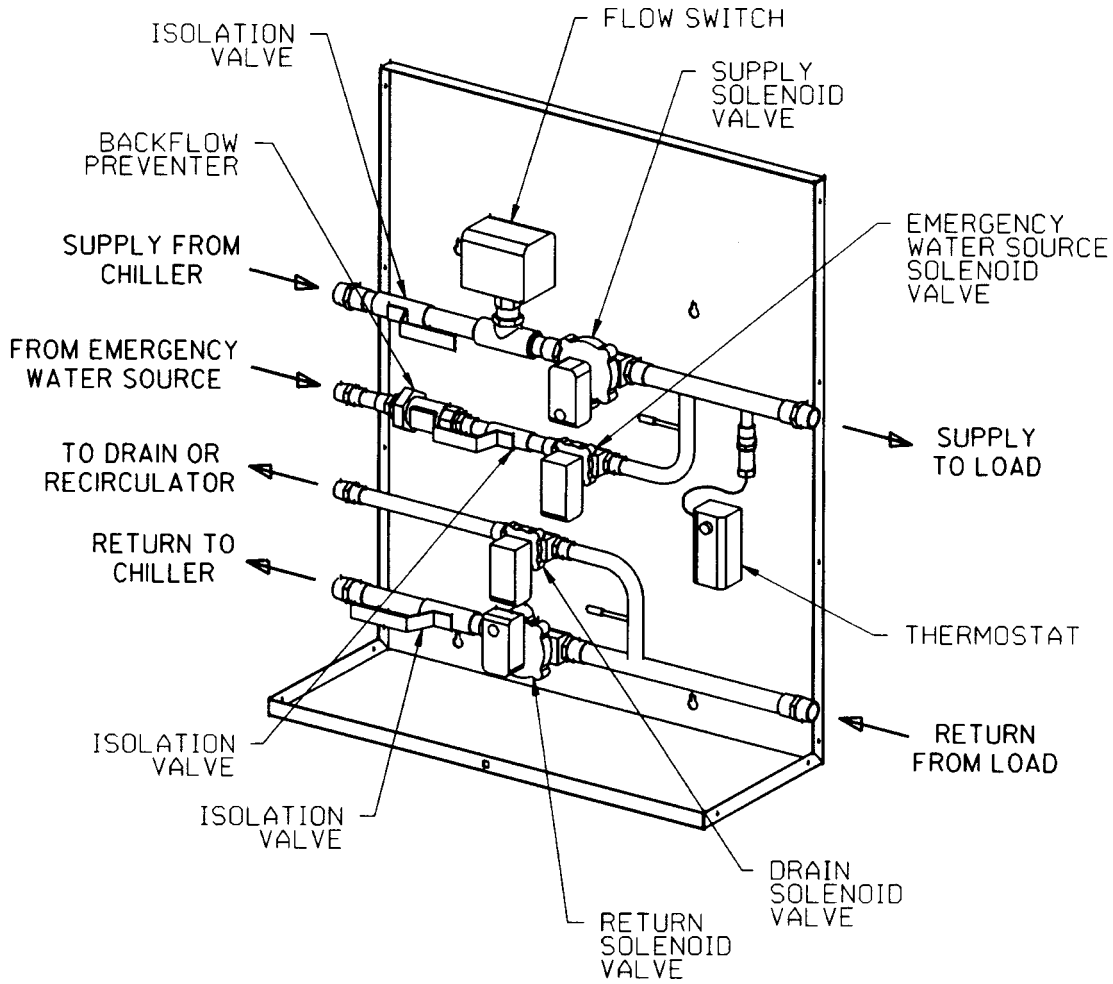
**To prevent leaks within the Emergency Water Source Module, the water pressure should not exceed 100 psig. For installations using an emergency water source above this rating, a pressure reducing valve (supplied by others) is required.**

Connect optional control wiring for remote shutdown and common alarm, as required. Plug module power cord into receptacle with appropriate rating. See **Figure 8**.

## 8.6 Maintenance

Periodic maintenance should include a monthly manual switch over to insure that the system operates properly.

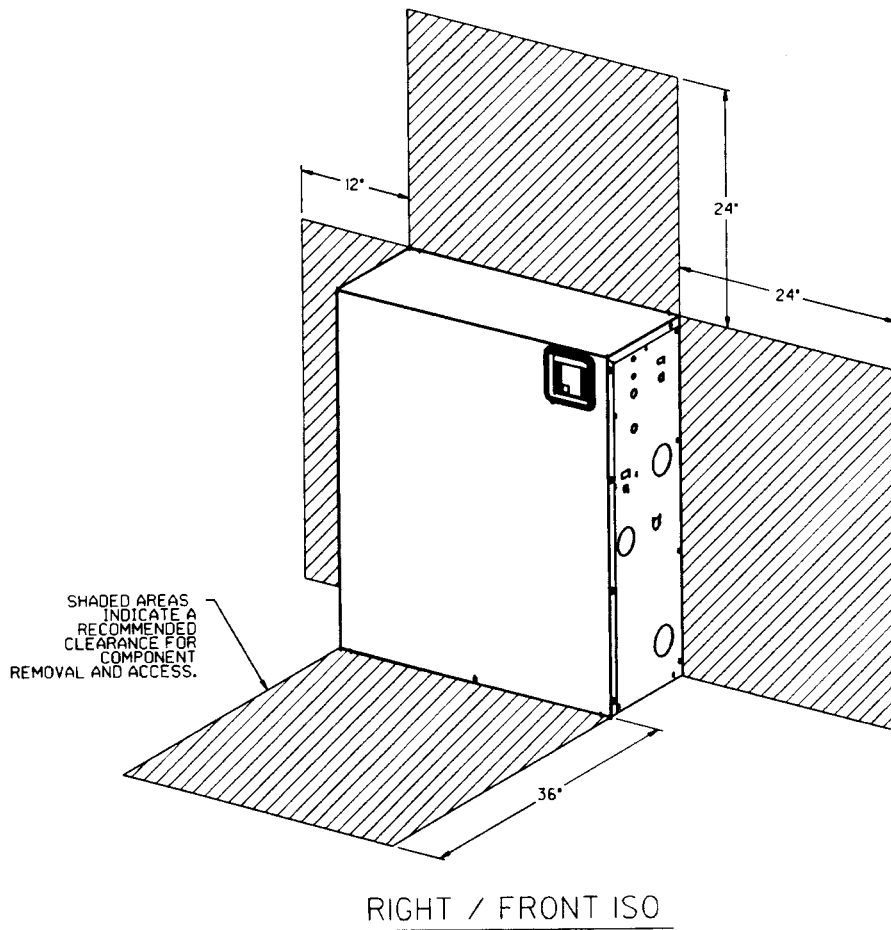
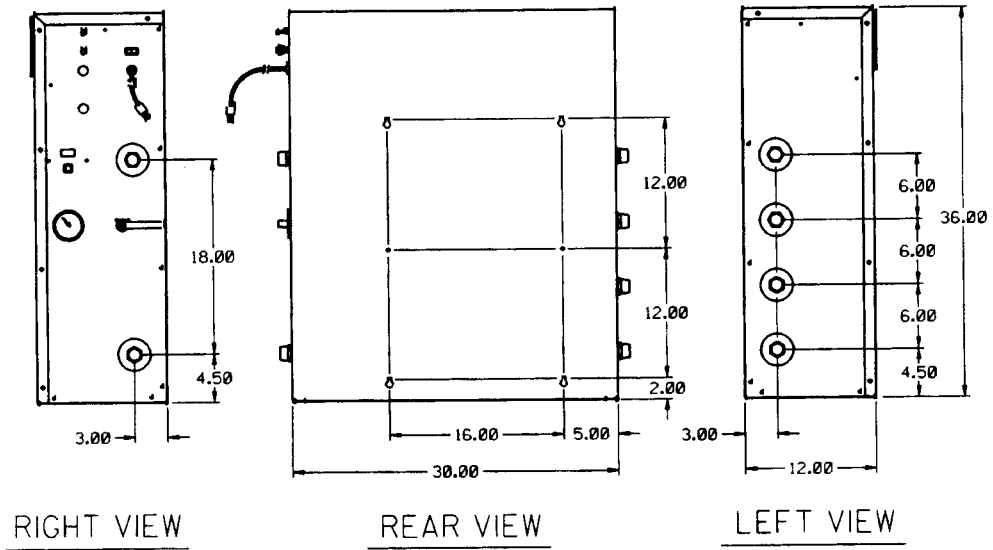
**Figure 6 General Piping Arrangement**



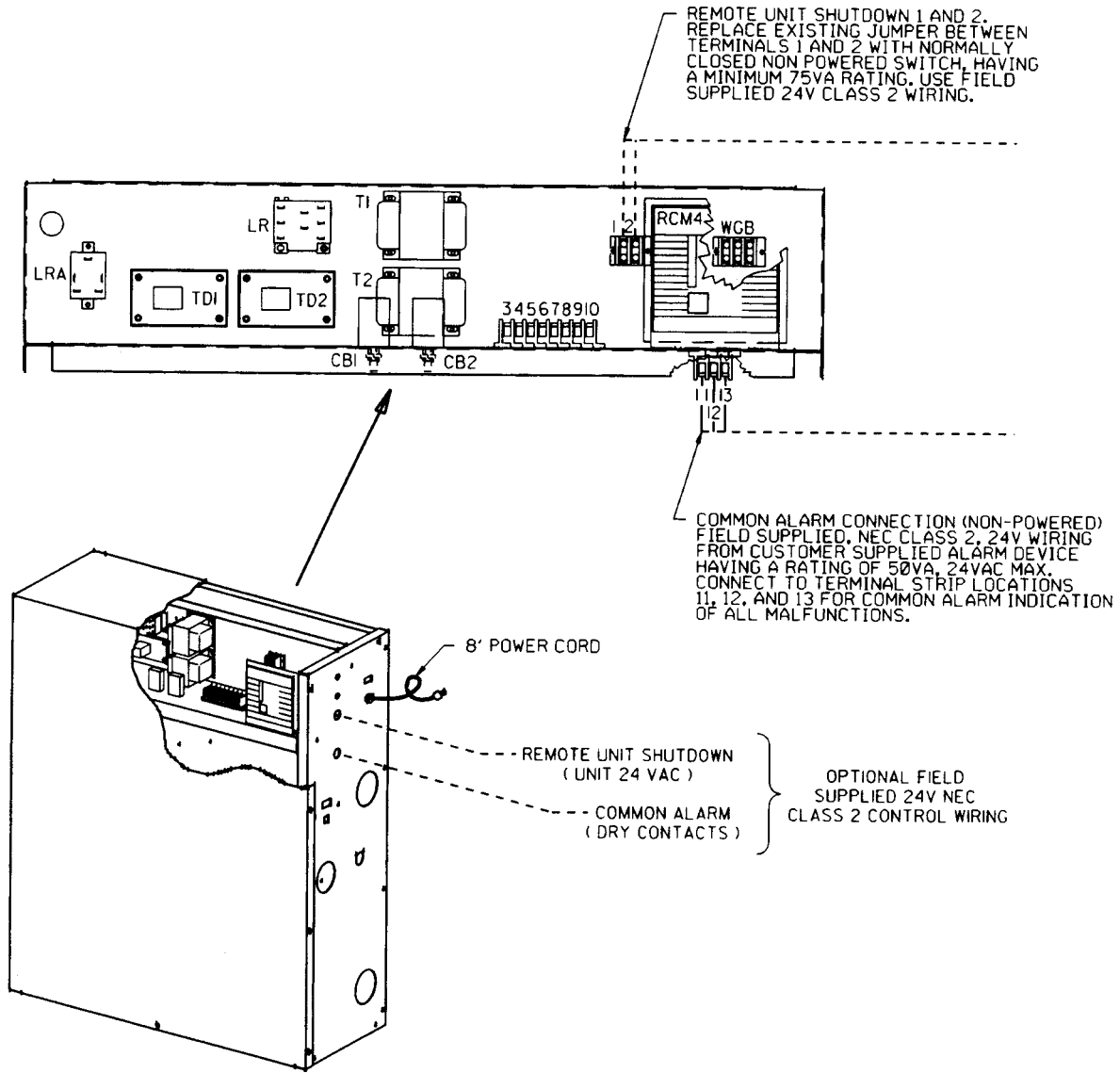
**Table 17 Emergency Water Source Piping Connection Sizes**

Connection	MPT
Supply from chiller	1"
From emergency water source	3/4"
To drain or recirculator	3/4"
Return to chiller	1"
Supply to load	1"
Return from load	1"

Figure 7 Cabinet Dimensions and Mounting



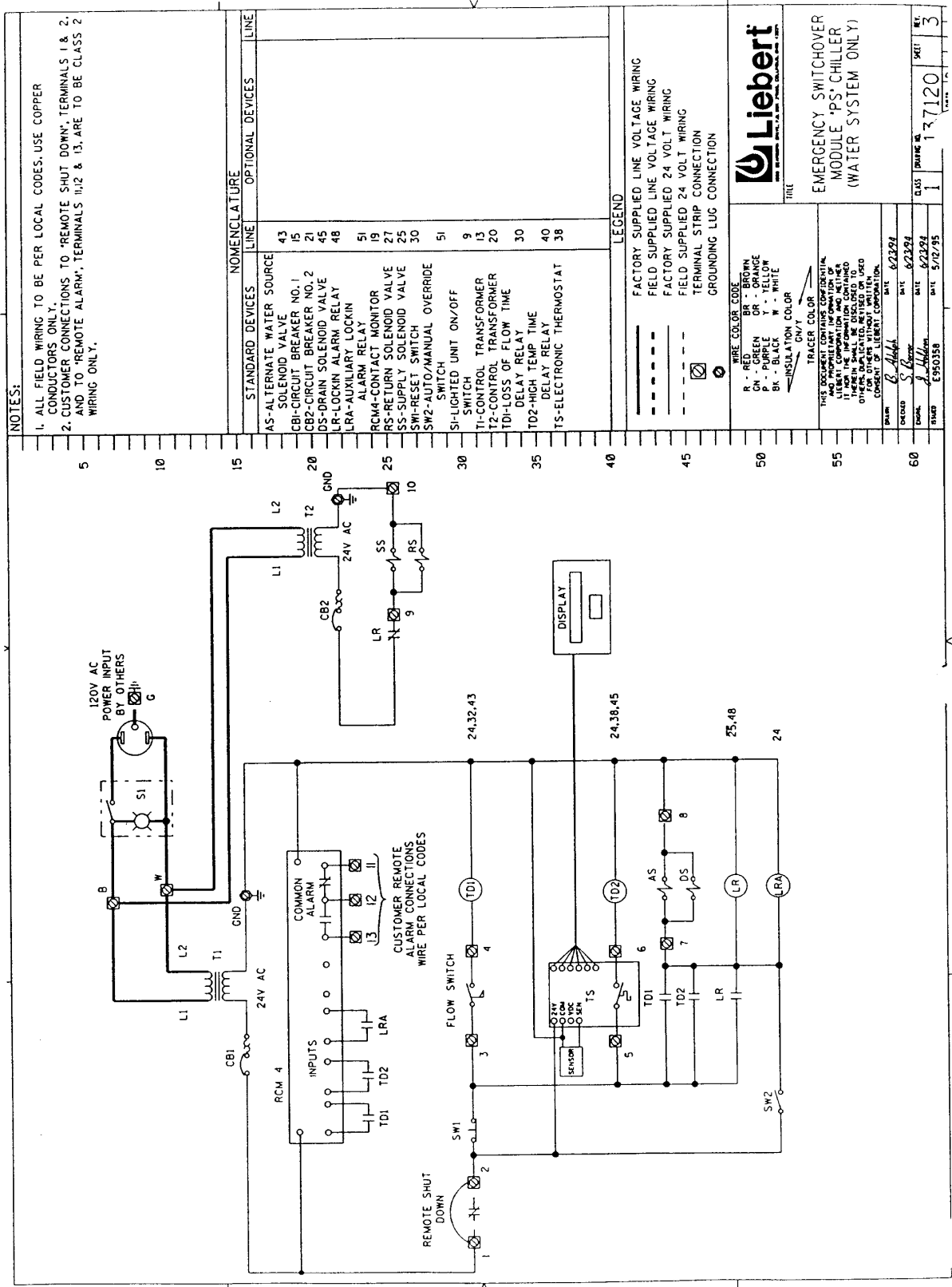
**Figure 8 Electrical Connections**



**Table 18 Emergency Water Source Electrical Data**

Input Voltage	115	V
Input Amps	.55	A
Minimum supply circuit ampacity	.69	A
Maximum fuse or circuit breaker	15	A
Transformer 1 secondary FLA	.55	A
Transformer 2 secondary FLA	.33	A

Figure 9 Emergency Switchover Electrical Schematic



NOTES:  
 1. ALL FIELD WIRING TO BE PER LOCAL CODES. USE COPPER CONDUCTORS ONLY.  
 2. CUSTOMER CONNECTIONS TO 'REMOTE SHUT DOWN', TERMINALS 1 & 2, AND TO 'REMOTE ALARM', TERMINALS 11, 12 & 13, ARE TO BE CLASS 2 WIRING ONLY.

NOMENCLATURE	
LINE	OPTIONAL DEVICES
43	AS-ALTERNATE WATER SOURCE SOLENOID VALVE
15	CB1-CIRCUIT BREAKER NO. 1
21	CB2-CIRCUIT BREAKER NO. 2
45	DS-DRAIN SOLENOID VALVE
48	LR-LOCK-IN ALARM RELAY
51	LRA-AUXILIARY LOCK-IN ALARM RELAY
19	RCM4-CONTACT MONITOR
27	RS-RETURN SOLENOID VALVE
25	SS-SUPPLY SOLENOID VALVE
30	SW1-RESET SWITCH
51	SW2-AUTO/MANUAL OVERRIDE SWITCH
9	SW3-LIGHTED UNIT ON/OFF SWITCH
13	T1-CONTROL TRANSFORMER
20	T2-CONTROL TRANSFORMER
30	TD1-LOSS OF FLOW TIME DELAY RELAY
40	TD2-HIGH TEMP TIME DELAY RELAY
38	TS-ELECTRONIC THERMOSTAT

LEGEND

- FACTORY SUPPLIED LINE VOLTAGE WIRING
- FIELD SUPPLIED LINE VOLTAGE WIRING
- FACTORY SUPPLIED 24 VOLT WIRING
- FIELD SUPPLIED 24 VOLT WIRING
- TERMINAL STRIP CONNECTION
- GROUNDING LUG CONNECTION

**Wire Color Code**

R - RED BR - BROWN  
 GN - GREEN OR - ORANGE  
 P - PURPLE Y - YELLOW  
 BK - BLACK W - WHITE

**Tracer Color**

TRACER COLOR  
 (THIS DOCUMENT CONTAINS CONFIDENTIAL AND PROPRIETARY INFORMATION OF LIEBERT INC. AND ITS AFFILIATES. IT IS TO BE USED ONLY FOR THE PROJECT AND FOR THE OTHERS AUTHORIZED BY LIEBERT INC. FOR OTHERS WITHOUT WRITTEN CONSENT OF LIEBERT INC.)

DATE: 8/22/94  
 DRAWN: S. B. B. DATE: 8/22/94  
 CHECKED: S. B. B. DATE: 8/22/94  
 DESIGNED: E. S. S. DATE: 5/12/95

**Liebert**  
 EMERGENCY SWITCHOVER  
 MODULE 'PS' CHILLER  
 (WATER SYSTEM ONLY)

CLASS: 1 DRAWING NO.: 137120 SHEET: 3

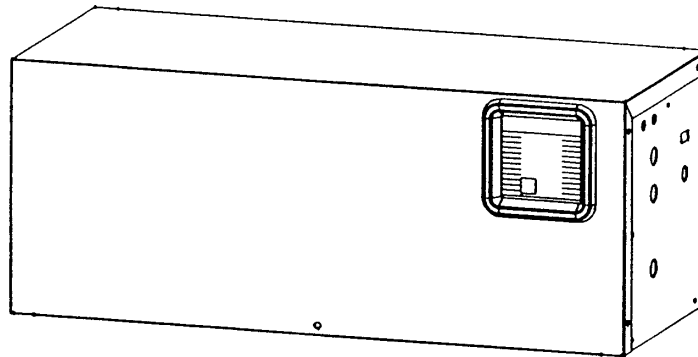
---

## 9.0 APPENDIX B: THE WATER LEVEL CONTROL MODULE

---

This module automatically adds water to the chiller system if the fluid level drops in the fluid reservoir located within the chiller. The module is a pre-piped and wired assembly which consists of an almond colored, powder coated and baked enclosure, RCM4 monitor, adjustable time delay relays, double check valve back flow preventer and flow regulating solenoid valve. Included for field installation and wiring is a multi-point level switch, junction box and automatic air vent. The module has a local display for high fluid level, low fluid level, fluid fill problem and fluid fill lockout. It also has a non-powered common alarm contact. It requires a 120-volt single-phase power input. This module is for use on systems that circulate water as the cooling medium (it is not for use with glycol systems).

**Figure 10 Water Level Control Module**

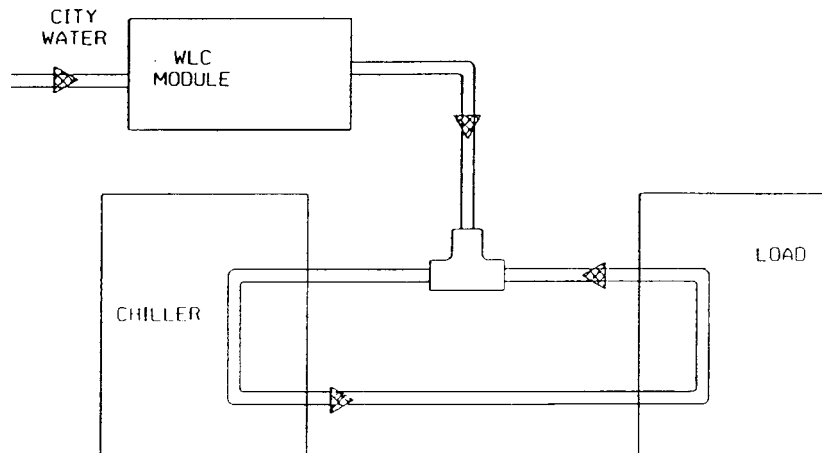


### 9.1 Model Number

WLC00W-K00 for application with 1.5 and 5 ton

### 9.2 Typical Application

**Figure 11 Water Level Control and Chiller System**



### 9.3 Sequence of Operation

In normal operation mode, the Water Level Control Module is in a standby mode while sensing an acceptable level of water in the reservoir within the chiller.

When the multi-point float switch installed in the water reservoir drops to the BEGIN FILL level, the flow limiting solenoid valve is activated within the Water Level Control Module (VLC) and

---

city water flows to fill the chiller system. This solenoid is deactivated when the float switch rises to the END FILL level that should occur in less than 4 minutes. If after 4 minutes of filling the END FILL level has not been reached an alarm is sounded on the RCM4 indicating a possible problem with the fill system requiring attention. The WLC module continues to attempt to fill the system for 4 more minutes (8 total minutes from first BEGIN FILL) after this first alarm at which time a second alarm is sounded on the RCM4, the fill system is locked out and attempts to fill the system cease until the lock out is MANUALLY RESET.

### Time Delay Settings (seconds)

Condition	Factory	Minimum	Maximum
Fill System Problem (TDRA)	240	1	600
Fill System Lockout (TDRB)	480	1	600

The WLC module also alarms through the RCM4 on conditions of LOW FLUID and HIGH FLUID in the reservoir. These alarms respectively indicate water levels below the BEGIN FILL level and above the END FILL level. The LOW FLUID and HIGH FLUID alarms must be MANUALLY RESET at the WLC module.

All alarms enunciated by the RCM4 also active the common alarm contacts on this device.



#### NOTE

*The “remote shutdown” function (see **Figure 14**) prevents operation of all WLC module functions and alarms regardless of status.*

## 9.4 System Components

**RCM4 Monitor.** Configured to activate an LED, an audible alarm, and switch the common alarm output contacts in response to a Fill System Problem, Fluid Fill Lockout, High Fluid Level and Low Fluid Level. The silence/reset button silences the alarm. The button also resets the LED's and contacts if the unit has returned to normal mode.

**Solenoid Valve.** 24 VAC, 2-way, direct operated, with brassbody. Includes an integral serviceable strainer and limits the waterflow rate to 0.5 gpm.

**Backflow Preventer.** Double-check design, located inside the “city water” piping connection point on the WLC module. Multi-point Level Switch consists of (4) relevel switches mounted in a single assembly that includes a 1 inch NPT fitting for mounting. This switch is shipped loose with the WLC module and must be field installed into the water reservoir of the process chiller. (8) wiring connections are field made between this device and the WLC module.

**Automatic Air Vent.** Shipped loose with the WLC module and must be field installed into the water piping of the chiller. It automatically vents air from the system which will enter the system with each water fill.



#### NOTE

*Trapped air will rise to the highest point in the system. It is recommended that additional automatic air vents be added to the system at appropriate locations.*

## 9.5 Installation

Prepare the location for the module. Since this device and the chiller must contain only water both must be kept from freezing. Allow adequate clearance for convenient maintenance (see



---

**Figure 13.)** Set unit on the floor or bolt securely to the wall using the key hole slots in the WLC module and appropriate anchors (supplied by others).



**WARNING**

**FAILURE TO FASTEN UNIT SECURELY TO WALL STUDS OR STRUCTURAL MEMBERS WITH APPROPRIATE ANCHORS (SUPPLIED BY OTHERS) MAY RESULT IN PRODUCT FAILURE AND HUMAN INJURY.**

At the chiller, remove the top panel over the chiller section. Make sure there is not water pressure in the system. Install the multi-point level switch into the top of the chiller fluid reservoir. (refer to **Figure 15.**) Use an appropriate pipe sealant. Attach the 2 x 4 junction box to the top of the multi-point level switch. Attach and route wiring from the level switch to the WLC module (see **Figure 14**) A knockout is provided in the piping connection panel on the left side of the chiller through which to route this wiring.

Install the automatic air vent in the return line to the chiller water reservoir. A 1/4 NPT pipe thread is provided in this line. Use an appropriate pipe sealant. The air vent must be installed vertically for proper operation.



**NOTE**

*Automatic air vents should be installed at all high points in the system or where ever air might be trapped. Failure to vent unwanted air can cause poor system performance.*



**CAUTION**

**Water pressure should not exceed 100 psig. For installations using a water source above this rating, a pressure reducing valve (supplied by others) is required.**

Connect city water to the appropriate connection on the WLC module as shown on **Figure 12.** The line should be sized to carry 0.5 gpm. Connect a similar line from the WLC module to an appropriate location in the chilled water system. A 1/4 NPT connection is located on the return water line in the chiller for this purpose if suitable (see **Figure 15**).

Connect optional control wiring for remote shutdown and common alarm, as required. Plug module power cord into receptacle with appropriate rating, (see **Figure 14**).



**NOTE**

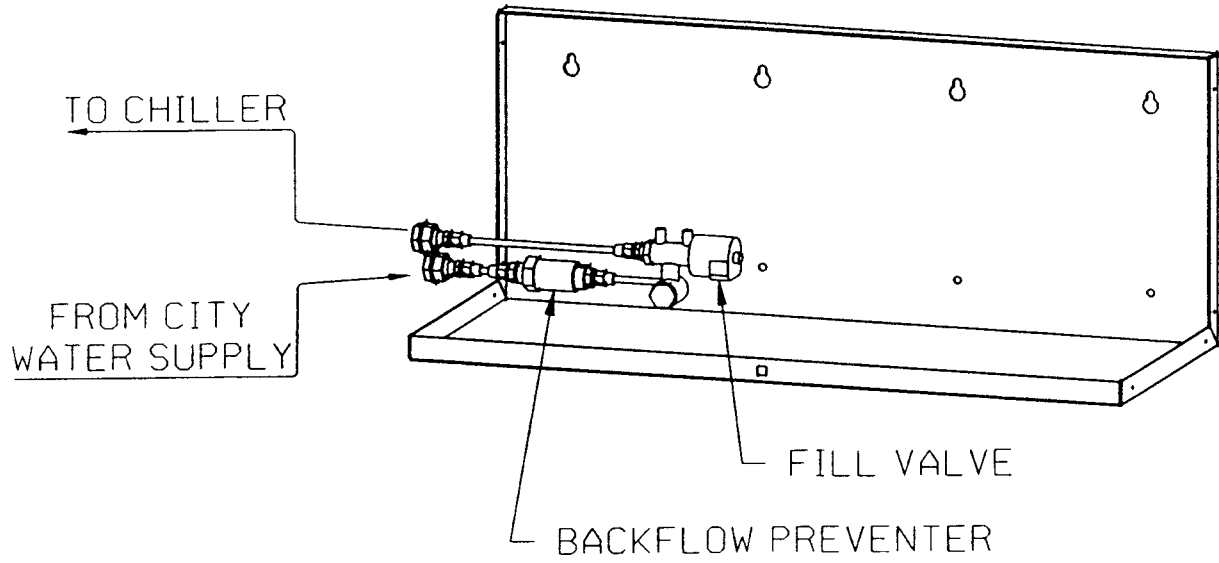
*Once connected and operational the WLC module may be used to initially fill the system with water. However, manual reset using the reset switch on the WLC module and alarm silence on the RCM4 will be required every 8 minutes during this initial system fill.*

Allow WLC to fill system, or fill manually, referring to chiller installation instructions in **2.3 - Piping Connections.** The expansion air volume must be maintained in the top of the reservoir tank for the WLC float switch to operate properly. Refer to **4.5 - Reservoir Tank** for maintenance recommendations.

## **9.6 Maintenance**

Periodic maintenance should include a monthly observation to verify that the electrical system is energized and that the water supply line is open.

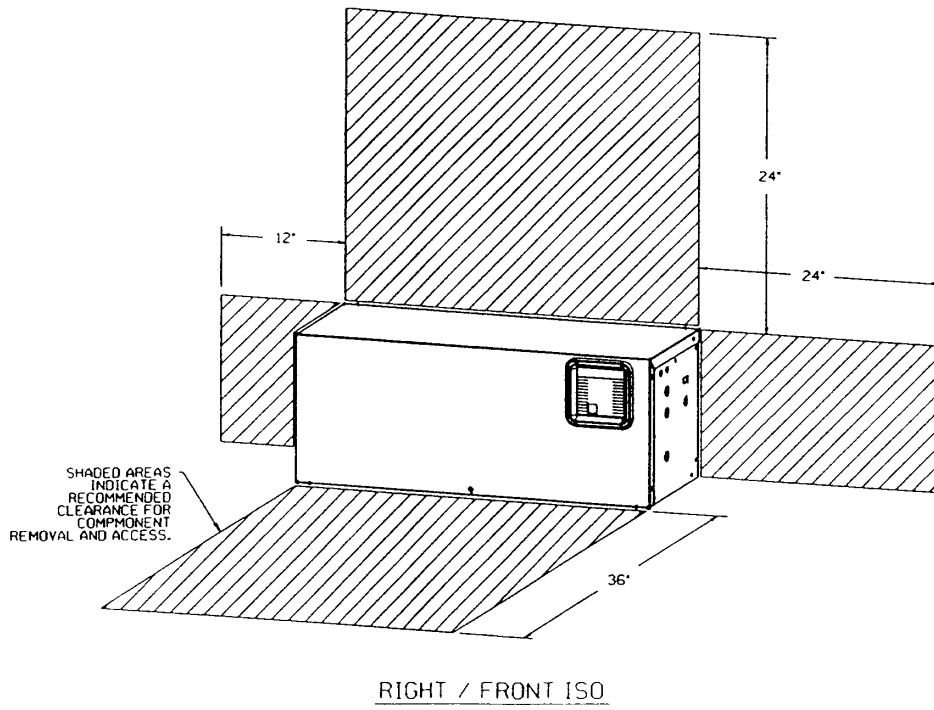
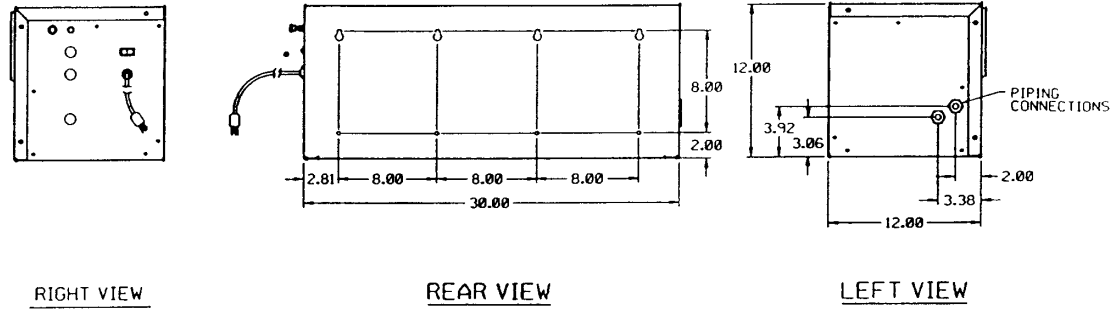
**Figure 12 General Piping Arrangement at WLC Module**



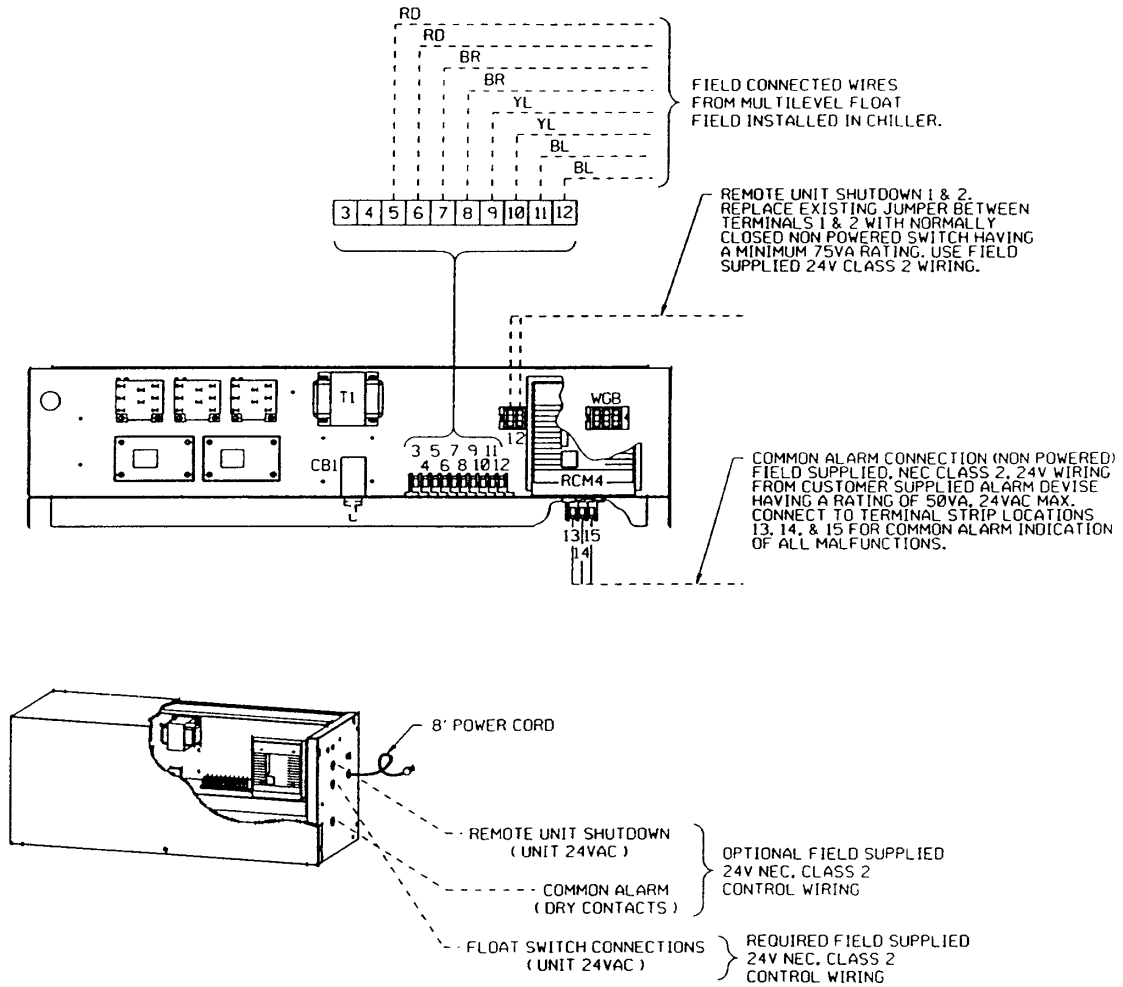
**Table 19 WLC Module Connection Sizes**

Supply Pressure, 100 psig Max	
Connection	FPT
Supply from city water source	1/4"
To chiller water system	1/4"

Figure 13 Cabinet Dimensions and Mounting



**Figure 14 Electrical Connections at WLC Module**



**Table 20 WLC Module Electrical Data**

Input Voltage	115 V
Input Amps	0.46 A
Minimum Supply Circuit Ampacity	0.58 A
Maximum Fuse or Circuit Breaker	15 A

Figure 15 Electrical and Piping Connections at the Process Chiller

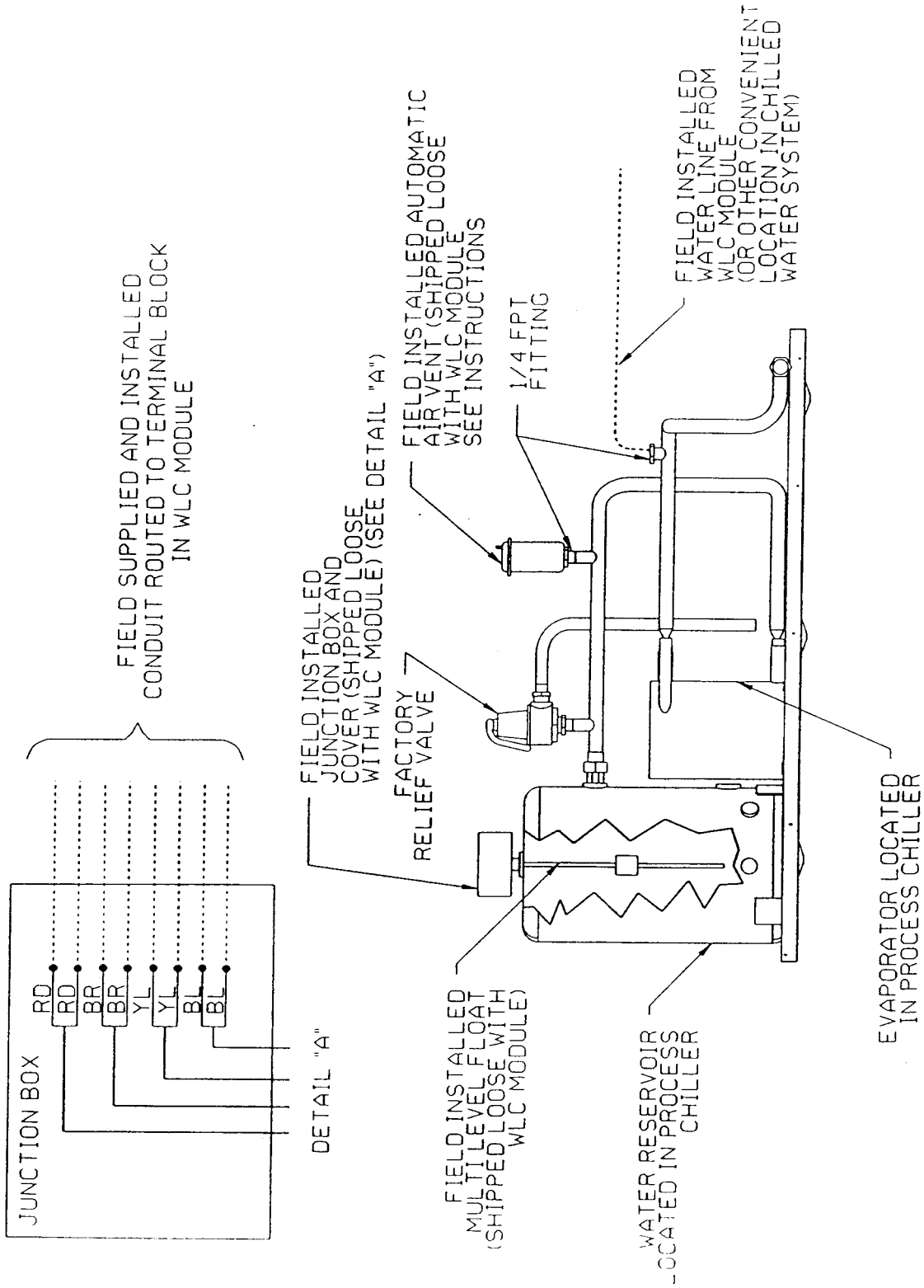
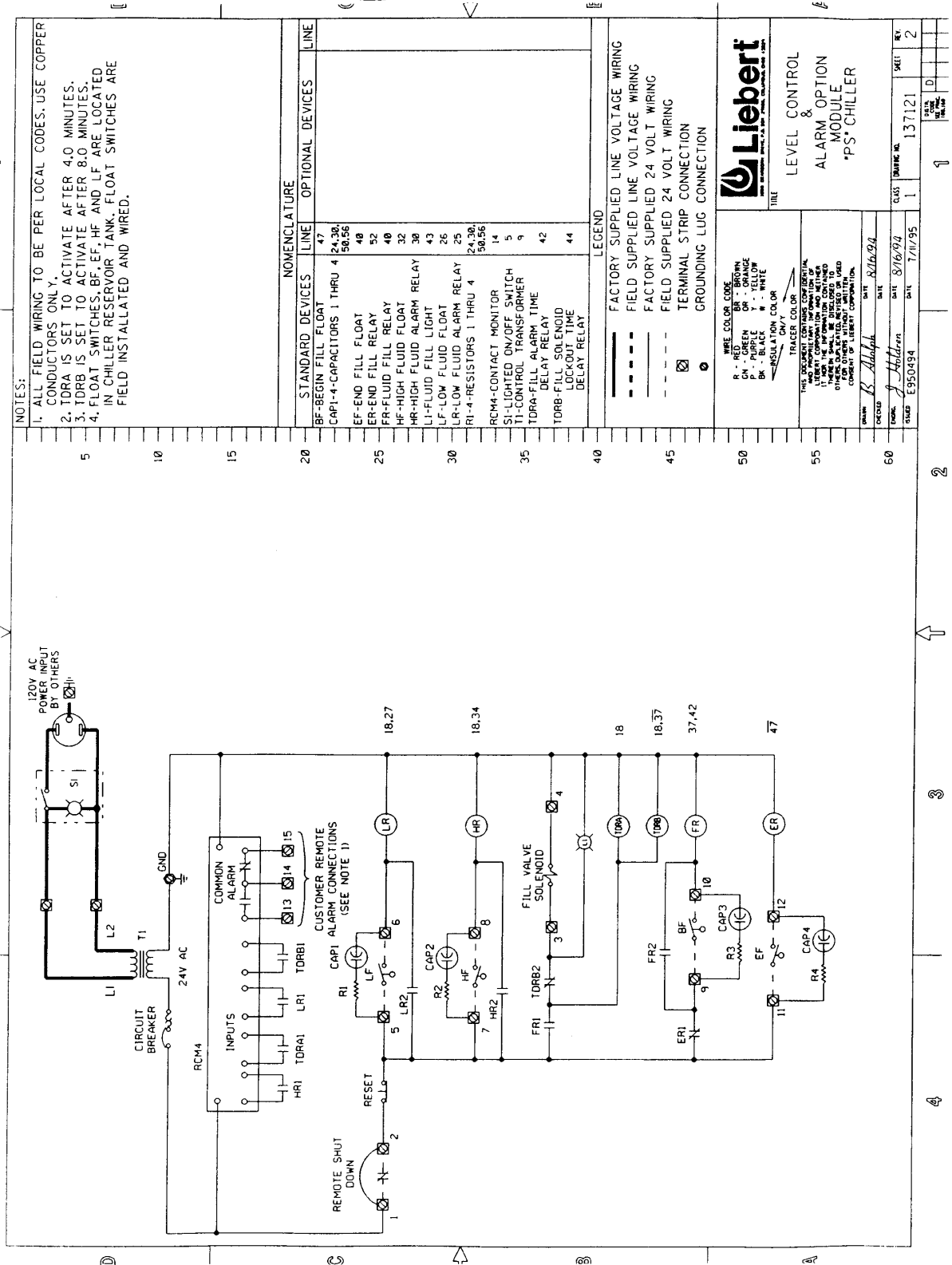


Figure 16 Level Control and Alarm Option Module Electrical Schematic





# Ensuring The High Availability Of Mission-Critical Data And Applications.

Emerson Network Power, the global leader in enabling business-critical continuity, ensures network resiliency and adaptability through a family of technologies—including Liebert power and cooling technologies—that protect and support business-critical systems. Liebert solutions employ an adaptive architecture that responds to changes in criticality, density and capacity. Enterprises benefit from greater IT system availability, operational flexibility and reduced capital equipment and operating costs.

## Technical Support / Service Web Site

[www.liebert.com](http://www.liebert.com)

### Monitoring

800-222-5877

[monitoring@emersonnetworkpower.com](mailto:monitoring@emersonnetworkpower.com)

Outside the US: 614-841-6755

### Single-Phase UPS

800-222-5877

[upstech@emersonnetworkpower.com](mailto:upstech@emersonnetworkpower.com)

Outside the US: 614-841-6755

### Three-Phase UPS

800-543-2378

[powertech@emersonnetworkpower.com](mailto:powertech@emersonnetworkpower.com)

### Environmental Systems

800-543-2778

Outside the United States

614-888-0246

### Locations

#### United States

1050 Dearborn Drive

P.O. Box 29186

Columbus, OH 43229

#### Europe

Via Leonardo Da Vinci 8

Zona Industriale Tognana

35028 Piove Di Sacco (PD) Italy

+39 049 9719 111

Fax: +39 049 5841 257

#### Asia

7/F, Dah Sing Financial Centre

108 Gloucester Road, Wanchai

Hong Kong

852 2572220

Fax: 852 28029250

While every precaution has been taken to ensure the accuracy and completeness of this literature, Liebert Corporation assumes no responsibility and disclaims all liability for damages resulting from use of this information or for any errors or omissions.

© 2006 Liebert Corporation

All rights reserved throughout the world. Specifications subject to change without notice.

® Liebert and the Liebert logo are registered trademarks of Liebert Corporation. All names referred to are trademarks or registered trademarks of their respective owners.

SL-16530\_REV1\_08-06

## Emerson Network Power.

The global leader in enabling Business-Critical Continuity™.

- |                    |                                |                             |                    |
|--------------------|--------------------------------|-----------------------------|--------------------|
| ■ AC Power Systems | ■ Embedded Computing           | ■ Outside Plant             | ■ Services         |
| ■ Connectivity     | ■ Embedded Power               | ■ Power Switching & Control | ■ Site Monitoring  |
| ■ DC Power Systems | ■ Integrated Cabinet Solutions | ■ Precision Cooling         | ■ Surge Protection |

[EmersonNetworkPower.com](http://EmersonNetworkPower.com)

Business-Critical Continuity, Emerson Network Power and the Emerson Network Power logo are trademarks and service marks of Emerson Electric Co.

©2006 Emerson Electric Co.